

Borough of Markleysburg
Fayette County, Pennsylvania

***SANITARY SEWER SYSTEM
RULES AND REGULATIONS***

Revised 9/6/2005

TABLE OF CONTENTS

| | | <u>Page No</u> |
|---------------|---|----------------|
| ARTICLE I | DEFINITIONS | 1 - 4 |
| ARTICLE II | DISCHARGE OF SANITARY SEWAGE TO PUBLIC SANITARY SEWAGE SYSTEM REQUIRED | 4 - 5 |
| ARTICLE III | EXCLUSION OF STORM WATER RUNOFF | 5 - 6 |
| ARTICLE IV | ADMISSION OF INDUSTRIAL WASTES TO PUBLIC SANITARY SEWAGE SYSTEM | 6 - 7 |
| ARTICLE V | UNACCEPTABLE SANITARY SEWAGE AND INDUSTRIAL WASTES | 7 - 9 |
| ARTICLE VI | SEWAGE COLLECTION, TRANSPORTATION AND TREATMENT CHARGES | 9 - 10 |
| ARTICLE VII | NO ABATEMENT OF RENTALS AND CHARGES | 10 |
| ARTICLE VIII | SURCHARGE FOR CERTAIN INDUSTRIAL WASTES | 11 - 13 |
| ARTICLE IX | BILLING AND COLLECTION | 13 |
| ARTICLE X | CONNECTIONS TO THE SYSTEM | 14 - 17 |
| ARTICLE XI | MAINTENANCE OF LATERALS AND BUILDING SEWER | 18 |
| ARTICLE XII | PROPOSED EXTENSIONS OF SYSTEM BY DEVELOPERS | 18 - 21 |
| ARTICLE XIII | CONNECTION OF EXISTING SEWAGE COLLECTION SYSTEMS | 22 - 24 |
| ARTICLE XIV | PROPOSED INDIVIDUAL HOUSE SERVICE PUMP INSTALLATIONS | 24 - 26 |
| ARTICLE XV | DELINQUENCIES, VIOLATIONS AND REMEDIES | 26 |
| ARTICLE XVI | INSPECTION BY THE BOROUGH | 27 |
| ARTICLE XVII | VALIDITY | 27 |
| ARTICLE XVIII | STANDARD DETAILS | 27 |
| ARTICLE XIX | TESTING | 28 - 29 |
| ARTICLE XX | SEWAGE FACILITIES RESTRICTIONS | 29 |

ARTICLE 1

DEFINITIONS

Unless the context specifically indicates otherwise, the following words and terms used in these Rules and Regulations shall have the following meanings:

Section 101. Abnormal Industrial Waste shall mean any industrial waste having a suspended solid content or B.O.D. appreciably in excess of that normally found in municipal sewage. For the purpose of these regulations any industrial waste containing more than 350 milligrams per liter of suspended solids, or having a B.O.D. in excess of 300 milligrams per liter, shall be considered an abnormal industrial waste regardless of whether or not it contains other substances in concentrations differing appreciably from those found in municipal sewage.

Section 102. **Borough** shall mean Borough of Markleysburg, County of Fayette, Commonwealth of Pennsylvania, the Borough Council of the Borough of Markleysburg duly elected as defined by the Borough Code.

Section 103. **Board or Council** shall mean the elected and appointed members of the Borough of Markleysburg, hereafter constituted, and its duly authorized agents or representatives.

Section 104. B.O.D. of Sewage or Industrial Waste shall designate its "Biochemical Oxygen Demand" and shall mean the quantity of oxygen utilized in the biochemical oxidation of the organic matter in said sewage or industrial waste under standard laboratory procedure in 5 days at 20 degree C, or expressed in milligrams per liter by weight. It shall be determined by one of the acceptable methods described in the latest edition of "Standard Methods for the Examination of Water and Wastewater", published jointly by the American Public Health Association, the American Water Works Association, and the Water Pollution Control Federation.

Section 105. Building sewer shall mean the extension from the sewer drainage system of any structure to the service lateral of a collection system.

Section 106. Collection sewer shall mean the **Borough's** collection of sanitary sewers located under highways, roads, streets, and rights-of-way with branch service laterals that collect and convey sanitary sewage or industrial wastes or a combination of both and into which storm, surface and ground waters are not intentionally admitted.

Section 107. This section left intentionally blank.

Section 108. Equivalent Dwelling Unit (EDU) shall mean the quotient of "Q" divided by 350 gallons per day, where Q is equal to the estimated average daily flow of sewage from the connected occupied building being considered.

Section 109. Garbage shall mean solid wastes from the preparation, cooking and dispensing of food and from the handling, storage and sale of produce.

Section 110. Industrial Wastes shall mean any solid, liquid, or gaseous substance, or water-borne wastes from industrial processes or commercial establishments, as distinct from sanitary sewage.

Section 111. May is permissive. (See "shall" Section 126.)

Section 112. Natural Outlet shall mean any outlet into a watercourse pond, ditch, lake, or other body of surface or groundwater.

Section 113. Occupied Building shall mean any structure erected and intended for continuous or periodic habitation, occupancy or use by human beings or animals, and from which structure sanitary sewage and industrial wastes, or either thereof, is or may be discharged.

Section 114. Owner shall mean any person vested with ownership, legal or equitable, sole or partial of any real estate or structure.

Section 115. Person shall include natural persons, partnerships, associations and corporations, public or private.

Section 116. pH shall mean the logarithm to the base 10 of the reciprocal of the hydrogen ion concentration expressed in moles per liter. It shall be determined by one of the acceptable methods described in the latest edition of "Standard Methods for the Examination of Water and Wastewater", cited above.

Section 117. Premises Accessible to the Public Sanitary Sewage System shall mean any real estate abutting on or adjoining or having access to any street, alley or right-of-way in which a sewer is located which ultimately connects to the public sanitary sewage system.

Section 118. Properly Shredded Garbage shall mean the wastes from the preparation, cooking and dispensing of food and from the handling, storage and sale of produce that have been shredded to such degree that all particles will be carried freely under the flow conditions normally prevailing in public sewers, with no particle greater than one-half inch ($\frac{1}{2}$ ") in any dimension.

Section 119. Public Sanitary Sewage System (sometimes called the "Sewer System") shall mean all sanitary sewers, all pumping stations, all force mains, all sewage treatment works, and all other sewage facilities owned or leased and operated by the **Borough** for the collection, transportation and treatment of sanitary sewage and industrial wastes, together with the appurtenances, and any additions, extensions or improvements thereto. It shall also include sewers within the **Borough's** service area which serve one or more persons and discharge into the public sanitary sewer system even though those sewers may not have been constructed by the **Borough**. It does not include separate storm sewers or culverts which have been constructed for the sole purpose of carrying storm and surface runoff, the discharge from which is not and does not become tributary to the sewage treatment facilities.

Section 120. Sanitary Sewage shall mean the normal water-carried household and toilet wastes from residences, business buildings, institutions, industrial and commercial establishments, exclusive of storm water runoff, surface water and groundwater.

Section 121. Sanitary Sewer shall mean a sewer which carries sewage and to which storm, surface and ground waters are not intentionally admitted.

Section 122. Service Lateral shall mean that part of the sewer system extending from a collection sewer to the property line, or, if no such service lateral shall be provided, then Service Lateral shall mean that portion of, or place in, a collection sewer which is provided for connection of any building sewer.

Section 123. Sewage shall mean a combination of water-carried wastes from residences, business buildings, institutions, and industrial and commercial establishments, together with such ground, surface or storm water as may be present.

Section 124. Sewer shall mean a pipe or conduit for carrying sewage.

Section 125. Sewer System Refer to definition of Public Sanitary Sewage System (Section 119).

Section 126. Shall is mandatory. (See "may", Section 111).

Section 127. Storm sewer shall mean a sewer which is intended to carry storm water runoff, surface waters and groundwater drainage but which is not intended to carry any sanitary sewage or polluted industrial waste.

Section 128. Storm Water Runoff shall mean that portion of the rainfall which reaches a channel, trench, sewer or sink.

Section 129. Suspended Solids shall mean solids that either float on the surface or are in suspension in water, sewage, industrial waste or other liquids, and which are removable by laboratory filtration. The quantity of suspended solids shall be determined by one of the acceptable methods described in the latest edition of "Standard Methods for the Examination of Water and Wastewater", cited above.

Section 130. Township means the Township of Henry Clay and Borough means the Borough of Markleysburg, Fayette County, Pennsylvania, acting by and through its authorized representative.

Section 131. Unpolluted Water or Waste shall mean any water or waste containing none of the following: free or emulsified grease or oil; pH less than 6.0 or greater than 9.0; phenols or other substances imparting taste and odor to receiving waters; toxic or poisonous substances in suspension, colloidal state or solution; obnoxious or odorous gases. It shall contain not more than 1,000 milligrams per liter by weight of dissolved solids of which not more than 250 milligrams per liter shall be as chloride and not more than 10 milligrams per liter each of suspended solids and B.O.D. The color shall not exceed 50 color units. Analyses for any of the above mentioned substances shall be made in accordance with the latest edition of "Standard Methods for the Examination of Water and Wastewater", cited above.

Section 132. Water Authority shall mean any publicly or privately owned duly authorized agency, corporation or organization which is the approved purveyor of the public water supply within the limits of the **Borough's** service area.

Section 133. Watercourse shall mean a channel in which a flow of water occurs, either continuously or intermittently.

ARTICLE II

DISCHARGE OF SANITARY SEWAGE TO PUBLIC SANITARY SEWAGE SYSTEM REQUIRED

Section 201. All persons owning any occupied building now erected within the **Borough's** service area upon premises accessible to the public sanitary sewage system shall, at their own expense, make connection with the public sanitary sewage system in accordance with the applicable Connection Ordinance in effect in the **Borough's** service area, if they are not presently so connected.

Section 202. All persons owning any premises within the **Borough's** service area accessible to the public sanitary sewage system upon which an occupied building is subsequently erected shall, at the time of erection of such building, and at their own expense, make connection with the public sanitary sewage system in accordance with the applicable Connection Ordinance in effect in the **Borough's** service area.

Section 203. All persons owning any occupied building within the **Borough's** service area upon premises which subsequently become accessible to the public sanitary sewage system shall, at their own expense, make connection with the public sanitary sewage system within the time period stipulated after proper notice to do so has been given in accordance with applicable law.

Section 204. All connections to the public sanitary sewage system shall be made in accordance with Article X hereof.

Section 205. No connection will be allowed with any cesspool, privy vault, septic tank, cistern or other depository. Such depositories, at a time of connection of the building to the sewer system, must be disconnected, with the inlet and outlet pipe capped with watertight seal. Any applicable state and township and Borough regulations pertaining to disposition of septic tanks must also be complied with. The **Borough** recommends, but does not require, that any abandoned septic tank be pumped out and refilled with sand, gravel or earth.

ARTICLE III

EXCLUSION OF STORM WATER RUNOFF

Section 301. The discharge of storm water runoff, surface water, groundwater, subsurface drainage, uncontaminated cooling water, downspouts and unpolluted industrial process water to sanitary sewers is prohibited.

Section 302. All persons connecting to the public sanitary sewage system shall provide and maintain adequate means for excluding water listed in Section 301 from the sanitary sewer.

Section 303. No person connected to a sanitary sewer shall connect any roof drain or foundation drain thereto or permit any such drains to remain connected thereto, nor shall he permit, allow or cause to enter into any sanitary sewer any spring water, surface water or unpolluted water from any other source.

Section 304. Connection to the sanitary sewer system will be denied if building drain shows presence of storm, surface, ground or other water.

Section 305. Owners of buildings already connected to the system where presence of storm, ground or other water source listed in Section 301 is detected shall be notified to correct condition within thirty (30) days. Failure to correct shall result in the **Borough** taking such corrective action as deemed necessary by the **Borough** at the cost and expense of the owners, together with ten percent (10%) additional thereof and all charges and expenses incidental thereto, which sum shall be collected from said owner or owners for the use of the **Borough** as debts are by now collectible.

Section 306. All sump pumps shall have discharge permanently piped to exterior of building using metal or plastic pipe. Sump pumps shall not discharge storm, surface, ground, or other water prohibited herein into the sanitary sewer system either directly or indirectly.

ARTICLE IV

ADMISSION OF INDUSTRIAL WASTES TO PUBLIC SANITARY SEWAGE SYSTEM

Section 401. The economy and desirability of the combined treatment of industrial wastes and sanitary sewage is recognized. In general, any and all industrial wastes may be discharged to the public sanitary sewage system except those which are deemed harmful to the system or are specifically prohibited by these Rules and Regulations. However, it is also recognized that the treatment of abnormal industrial wastes may add to the cost of operating and maintaining the public sanitary sewage system. Such additional cost must therefore be borne by the person or persons receiving the benefit of such treatment.

Section 402. The **Borough** reserves the right to refuse connection to the public sanitary sewage system for deleterious industrial wastes, or to compel discontinuance of the use of the system for such wastes, or to require pretreatment and/or equalization of flow thereof in order to prevent harmful or adverse effects upon the system. The design, construction and operation of such pretreatment and/or flow equalization facilities shall be made at the sole expense of the person discharging said wastes and shall be subject to the approval of the **Borough** or its designated representative.

Section 403. In general, industrial waste shall be considered harmful to the public sanitary sewage system if it may cause any of the following damaging effects:

- A. Chemical reaction either directly or indirectly with the materials of construction of the public sanitary sewage system in such a manner as to impair the strength or durability of any sewage structures.
- B. Mechanical action that will destroy any sewage structures.
- C. Restriction of the hydraulic capacity of any sewage structures.
- D. Restriction to the normal inspection or maintenance of any sewage structure.
- E. Danger to public health and safety.
- F. Obnoxious conditions inimical to the public interest.
- G. Substances that are toxic to the normal biological activity required to treat domestic sewage.

Section 404. When required by the **Borough**, any person discharging to the public sanitary sewage system any industrial wastes, or industrial wastes and sanitary sewage together, shall install a suitable manhole or manholes or metering chamber on his connecting sewer or sewers to facilitate observations, sampling and measurement of the combined flow or wastes from his premises. Such manhole or manholes or metering chamber shall be accessible and safely located and shall be constructed in accordance with plans approved by the **Borough** or its designated representative. The manhole or manholes or metering chamber shall be installed by such person at his expense and shall be maintained by him so as to be safe and accessible to the **Borough** or its designated representative at all times. The construction and maintenance of such manhole or metering chamber shall be mandatory for the producers of abnormal industrial wastes, and if deemed necessary by the **Borough**, flows from such manhole or metering chamber shall be continuously monitored, transmitted and recorded by means of an approved receiving device to be located at the treatment plant.

Section 405. Grease, oil, and sand interceptors shall be provided when, in the opinion of the **Borough** or Inspector, they are necessary for the proper handling of liquid wastes containing grease in excessive amounts, or any flammable wastes, sand or other harmful ingredients; except that such interceptors shall not be required for private living quarters or dwelling units. All interceptors shall be of a type and capacity approved by the **Borough** and shall be located as to be readily and easily accessible for cleaning and inspection.

ARTICLE V

UNACCEPTABLE SANITARY SEWAGE AND INDUSTRIAL WASTES

Section 501. The discharge of excessive amounts of unpolluted water or waste to a sanitary sewer is expressly prohibited. However, such discharges to storm sewers will be permitted wherever such storm sewers are of adequate capacity. The **Borough** reserves the right to define the amount it deems excessive in each particular instance.

Section 502. The discharge of garbage to the public sanitary sewage system is expressly prohibited unless the garbage is properly shredded garbage.

Section 503. No sanitary sewage or industrial waste from any property other than that for which a permit has been issued as provided in Article X hereof shall be discharged to the public sanitary sewage system.

Section 504. No person shall discharge to the public sanitary sewage system any sanitary sewage or industrial waste having any of the following characteristics:

- A. Wastes containing liquids, solids or gases which by reason of their nature or quality may cause fire, explosions, or be in any other way injurious to persons, the structures of the public sanitary sewage system or its operation.

- B. Wastes having a temperature in excess of 150 degrees F or less than 32 degrees F.
- C. Wastes having a pH lower than 5.5 or higher than 9.0 or having any corrosive properties capable of causing damage or hazards to structures, equipment or personnel of the public sanitary sewage system. Where the **Borough** deems it advisable, it may require any person discharging industrial wastes to install and maintain, at his own expense, in a manner approved by the **Borough** or its designated representative, a suitable device to continuously measure and record the pH of the wastes so discharged.
- D. Wastes containing any noxious or malodorous gas or substance which either singly or by interaction with sewage or other wastes is, in the opinion of the **Borough**, likely to create a public nuisance or hazard to life, or prevent entry to sewage structures for their maintenance and repair.
- E. Wastes containing ashes, cinders, sand, mud, straw, shavings, metal, glass, rags, feathers, tar, plastics, wood, hair, chemical or paint residues, greases, lime slurry or viscose materials of such character or in such quantity that, in the opinion of the **Borough**, they may cause an obstruction to the flow in the sewers or otherwise interfere with the proper operations of the public sanitary sewage system. Attention is called to the fact that the maximum permissible concentration will vary throughout the public sanitary sewage system depending upon the size of the particular interceptor sewer receiving the same and the flows therein.
- F. Wastes containing insoluble, non-flocculent substances having a specific gravity in excess of 2.65.
- G. Wastes containing soluble substances in such concentration as to cause the specific gravity of the waste to be greater than 1.1
- H. Wastes containing any of the following substances in solution or in suspension in concentrations exceeding those shown in the following table:

| <u>Substance</u> | <u>Maximum Permissible Concentration</u> |
|--|--|
| Phenolic compounds as C ₅ H ₆ OH | 1.0 mg./L |
| Cyanides as CN | 0.0 mg./L |
| Cyanides as CNO | 0.0 mg./L |
| Iron as Fe | 0.3 mg./L |
| Trivalent Chromium as Cr plus Hexavalent Chromium as Cr | 0.5 mg./L |
| Nickel as Ni | 1.0 mg./L |
| Copper as Cu | 0.03 mg./L |
| Lead as Pb | 0.5 mg./L |
| Zinc as Zn | 0.15 mg./L |

ARTICLE VI

SEWAGE COLLECTION, TRANSPORTATION AND TREATMENT CHARGES.

Section 601. There is imposed upon the owners of, or the users of water in or on, all properties served by the public sanitary sewage system, sewage collection, transportation and treatment charges for the use of said system, payable in the amounts and as provided for in the Sewer Rate Resolution heretofore adopted by the **Borough** and as it is hereinafter from time to time amended and modified. Said owners and users will be jointly and severally liable for the payment of said sewage collection, transportation and treatment charges and the penalties therein prescribed for delinquent payments thereof.

Section 602. All bills for sewage collection, transportation and treatment charges shall be due and subject to the penalty provisions as set forth in the **Borough's** Sewer Rate Resolution. All bills will be sent to property owner's address of record according to the local tax collector records. Owners will be billed periodically for the sewage collection, transportation and treatment charges in accordance with the billing practices of the **Borough**.

Section 603. The **Borough's** initial collection, transportation and treatment charges shall be on a flat rate basis in accordance with its Sewer Rate Resolution. The **Borough** may, if it deems it advisable, elect at some time in the future to impose, in whole or in part, the sewage collection, transportation and treatment charges on such other basis as it may determine. When water usage is used as the basis for said charges, the volume of water to be used for billing purposes shall be based upon water meter readings of the Water authority or in the absence of such readings, upon estimates made by the **Borough** or flat rate charges.

Section 604. When water usage is used as the basis of charges, then if an owner or user obtains part or all of the water used in or on a property from sources other than the Water authority, such owner or user may, after written approval from the **Borough**, at no expense to the **Borough** or the Water Authority, install and maintain a water meter or meters satisfactory to the **Borough** and the Water Authority for measuring all water used other than that obtained from the Water authority, and the quantity of water used to determine the sewage collection, transportation and treatment charges shall be the quantity of water measured by all such meters plus the quantity of water obtained from the Water Authority. In lieu of such additional meters, the **Borough** may establish under the Sewer Rate Resolution a flat rate charge which shall be applicable to such non-metered water usage.

Section 605. When water usage is used as the basis of charges, then if it is established to the satisfaction of the **Borough** that a portion of the water used in or on any property served by the public sanitary sewage system does not and cannot enter said system, and in the event that the total water used in or on said property exceeds 100,000 gallons per quarter, the **Borough** may determine, in such manner and by such method as it may deem practical, the percentage of the water entering the public sanitary sewage system, or the **Borough** may require or permit the installation of additional meters in such manner as to determine either the quantity of water excluded from the public sanitary sewage system or the quantity of water, sewage or industrial waste actually entering the public sanitary sewage system, exclusive of storm water runoff. In such case, the sewage collection, transportation estimated, measured or computed by the **Borough** to be actually entering the public sanitary sewage system, exclusive of storm water runoff.

ARTICLE VII

NO ABATEMENT OF RENTALS AND CHARGES

Section 701. There shall be no abatement of sewer rentals or service charges imposed by the Sewer Rate Resolution of the **Borough** unless the property with respect to which an abatement is requested shall have been permanently physically disconnected from the sewer system in a manner satisfactory to the **Borough**. It is intended by this Section to prohibit any abatement of sewer rentals or service charges for any period during which a property connected to the sewer system shall have been vacant or unoccupied unless the property is permanently physically disconnected, as aforesaid. Further, there shall be no abatement of sewer rentals or service charges imposed by the above-referenced Resolution during the time period in which an occupied building connected to the sewer system is seasonably vacant.

ARTICLE VIII

SURCHARGE FOR CERTAIN INDUSTRIAL WASTES

Section 801. Although the sewage treatment works will be capable of treating certain abnormal industrial wastes as heretofore defined in Article I, the actual treatment of such wastes may increase the cost of operating and maintaining the public sanitary sewage system. Therefore, there will be imposed upon each person discharging such industrial waste into the public sanitary sewage system a surcharge, or surcharges, which are intended to cover such additional cost. Such surcharges shall be in addition to the regular sewage collection, transportation and treatment charges set forth in the Sewer Rate Resolution of the **Borough**, and shall be payable as therein provided.

Section 802. The strength of any industrial waste, the discharge of which is to be subject to surcharge, shall be determined monthly, or more frequently as the **Borough** shall determine, from samples taken either at the manhole or metering chamber referred to in Article IV hereof, or at any other sampling point mutually agreed upon by the **Borough** and the producer of such waste. The frequency and duration of the sampling period shall be such as, in the opinion of the **Borough**, will permit a reasonably reliable determination of the average composition of such waste, exclusive of storm water runoff. Samples shall be collected or their collection supervised by a representative of the **Borough** and shall be in proportion to the flow of waste, exclusive of storm water runoff, and composited for analysis in accordance with the latest edition of "Standard Methods for the Examination of Water and Wastewater", cited above. Except as hereinafter provided, the strength of the waste so found by analysis shall be used for establishing the surcharge or surcharges. However, the **Borough** may, if it so elects, accept the results of routine sampling and analyses by the producer of such wastes in lieu of making its own samplings and analyses.

Section 803. In the event any industrial waste is found, by the **Borough**, to have a B.O.D. in excess of 300 milligrams per liter, the producer of said waste shall be surcharged an amount equal to the product of the actual volume of wastes in thousand gallons per billing period, exclusive of storm water runoff, discharged to the public sanitary sewage system and the "BOD surcharge rate". The "BOD surcharge rate" shall be determined by the following formula: $R_c = 0.00834 P (C - 300)$

Where $R_c =$ the BOD surcharge rate in cents per 1,000 gallons of waste discharged.

$P =$ the average annual fixed, operating and maintenance cost of secondary treatment processes per pound of BOD received at the treatment works. (Prior to completion of the first year of operation the value of "P" shall be assumed to be four (4) cents.)

$C =$ the average BOD of the industrial waste expressed in milligrams per liter as determined in accordance with Section 802 of this Article.

The figure 300 appearing in the above formula corresponds to the maximum BOD permissible without surcharge. The figure 0.00834 is the factor to convert milligrams per liter to pound per 1,000 gallons. No discount will be permitted for sewage or industrial wastes having a BOD less than 300 milligrams per liter.

Section 804. In the event any industrial waste is found, by the **Borough** to have an average suspended solids concentration in excess of 350 milligrams per liter, the producer of such waste shall be surcharged an amount equal to the product of the actual volume of wastes in thousand gallons per billing period, exclusive of storm runoff, discharged to the public sanitary sewage system and the "suspended solids surcharge rate". The "suspended solids surcharge rate" shall be determined by the following formula:

$$\text{Formula: } Rs = 0.00834 B (S - 350)$$

Where Rs= the suspended solids surcharge rate in cents per 1,000 gallons of waste discharged.

B = the average annual fixed, operating and maintenance cost of sludge digestion, sludge drying and sludge disposal operations per pound of suspended solids received at the treatment works. (Prior to completion of the first year of operation the value of "B" shall be assumed to be four (4) cents.)

S = the average suspended solids concentration of the abnormal industrial waste expressed in milligrams per liter as determined in accordance with Section 802 of this Article.

The figure 350 appearing in the above formula corresponds to the maximum suspended solids concentration permissible without surcharge. The figure 0.00834 is the factor to convert milligrams per liter to pounds per 1,000 gallons. No discount will be permitted for sewage or industrial wastes having a suspended solids concentration less than 350 milligrams per liter.

Section 805. The surcharges provided for in this Article shall be added to the sewage collection, transportation and treatment charges imposed by the **Borough** under the Sewer Rate Resolution.

ARTICLE IX

BILLING AND COLLECTION

Section 901. Bills and notices relating to the sewage collection, transportation and treatment charges and surcharges will be mailed or delivered to the property owner's last address, or where proper arrangements have been made with the **Borough**, to the user's last address, as shown on the billing books of the **Borough**. Should user(s) fail to pay within the allotted time, the owner of property served shall be held liable for payment.

ARTICLE X

CONNECTIONS TO THE SYSTEM

Section 1001. Application for connection to the public sanitary sewage system shall be made to the **Borough** upon the permit form to be formulated and furnished by the **Borough**.

Section 1002. All information requested on said form shall be furnished by the applicant, including the character and use of each structure located upon the property.

Section 1003. Any required tap connection and inspection fees shall be paid at the time of making application for permission to make a connection. Fees shall be in accordance with the **Borough's** Sewer Rate Resolution.

Section 1004. Upon receipt of a properly completed application for connection to the public sanitary sewage system, accompanied by any required tap connection and inspection fees, the **Borough** shall issue a sewer connection permit to the property owner for connection with said sewer.

Section 1005. No work shall commence before the payment of any aforementioned tap connection and inspection fee and issuance of the aforementioned connection permit.

Section 1006. Except as otherwise provided in this Section 1006, separate connections, and the corresponding tap connection and inspection fees, will be required for each individual occupied building, whether constructed as a detached unit or as one of a pair or row. Groupings of more than one equivalent dwelling unit on one building sewer shall not be permitted except under special circumstances and for good sanitary reasons or other good cause shown, and then only after special permission of the **Borough**, in writing, shall have been secured, and subject to such rules, regulations and conditions as may be prescribed by the **Borough**. Further, in the event a single house connection is permitted to serve a double house or condominium complex, it will be necessary for the property owners to sign an agreement (which the **Borough** may record in the office of the Recorder of Deeds) relieving the **Borough** of any responsibility or obligation caused by or resulting from installation of a single house connection. The agreement shall provide that any disagreement between the parties concerning future maintenance of the common sewer will be sufficient cause for the **Borough** to install additional connections to the sewer main to provide individual service. The installation of such separate service laterals from the sewer main to the property line, as well as the house building sewers from the property line to the occupied buildings, shall be made at the expense of the property owners signing the agreement. A single connection with payment of the tap connection fees for the appropriate number of equivalent dwelling units served will be permitted to serve a school, factory, apartment house or other permanent multiple use structure whose individual apartments or units may not be subject to separate ownership.

Section 1007. Following receipt of proper notice, customers abutting any completed part of the sewer system will be directed to connect to the system. Such customers shall be given a 60-day notice within which to make such connections. Sewer rentals will be charged after this 60-day period even though the customer has not completed his connection. However, the non-receipt of a notice to connect will not relieve an owner of improved property from his responsibility to connect within the time period allowed adjacent property owners. Customers desiring to improve a property and connect the property into the sewer system must file written application on forms furnished by the **Borough**. This application must be signed by the owner of the premises or his authorized agent and shall, together with these Rules and Regulations and amendments thereto, regulate and control sewer service for the premises.

Section 1008. All connections to the sanitary sewers shall be subject to certain restrictions as to unacceptable sanitary sewage which are set forth herein in Article V.

Section 1009. The designated Inspector of the **Borough** shall be given at least twenty-four (24) hours notice of the time when such connection shall be made in order that said Inspector can be present to inspect and approve the work of connection. The Inspector shall signify his approval of the connection by endorsing his name and the date of approval on the aforementioned connection permit in the possession of the permittees.

Section 1010. At the time of inspection of the connection, the owner or owners of properties shall permit the Inspector full and complete access to all sanitary and drainage arrangements and facilities in each building and in and about all parts of the property. Building sewer line shall not be covered over, or in any manner concealed, until after it is inspected and approved by said Inspector.

Section 1011. It is the intention of these Rules and Regulations that the entire connection be inspected at one time; however, if the property owner feels that special conditions warrant more than one inspection, he may request the same, subject to such additional inspection fees as the **Borough** shall determine.

Section 1012. Use of a new connection to the sewer system will not be permitted until the installation has been inspected and approved in accordance with the **Borough's** procedures.

Section 1013. Pipe and fittings used for the building sewer and service lateral shall be:

1. PVC polyvinyl chloride plastic sewer pipe, having either a rubber ring or a solvent cemented joint (ASTM D-3034, SDR-35) or (Schedule 40).

For building sewer and service laterals four inch (4") diameter pipe may be used where the line gradient is two percent (2%) or greater and six inch (6") diameter pipe shall be used where the line gradient is less than (2%). Pipe shall have permanently tight joints which shall prevent the admission of groundwater. No transformation from one pipe size or type will be made without the use of manufactured adapters designed specifically for the purpose and approved by the **Borough**. All changes in direction will be made with pipe fittings and no fittings greater than 45 degrees will be permitted.

Section 1014. All sewer pipe shall be installed in strict accord with the manufacturer's recommendations. Where rock trench foundation exists, a four (4) inch gravel cradle shall be provided under the pipe.

Section 1015. All pipe shall be installed with a minimum slope of one eighth (1/8) inch per foot for 6" diameter pipe, and one fourth (1/4) inch per foot for 4" diameter pipe. All pipe must have at least 30 inches of cover. Special protection must be given to pipe laid under driveways to avoid cracking or crushing. Under driveways, pipe shall be laid on a 6 inch sand and/or gravel base and backfilled with sand and/or gravel to at least 6 inches above top of pipe. All pipe shall be laid in a straight grade from the house connection to the **Borough's** service connection. All pipe shall be laid with full and even bearing and no block support will be allowed. Bell holes shall be dug to allow sufficient space to properly make each joint. Backfill shall be tamped uniformly around the pipe. All work shall be done in a workmanlike manner and shall provide a durable installation.

Section 1016. A trap either manufactured or site assembled, made from same size and pipe type material shall be installed approximately five feet (5') from the building. The trap shall be vented and the vent situated as not to allow the discharge of any surface water to the sanitary sewer. A view port shall be installed at the property or **Borough** easement line on the building sewer. The view port shall be a tee with a vertical riser pipe, so that the **Borough** or their agent will be able to check for infiltration or inflow.

Section 1017. Unless otherwise authorized by the **Borough** or its representative, cleanouts shall be provided in each building sewer at such intervals to permit complete rodding with a one hundred (100) foot long auger or tape. Such intervals shall include the length of the service lateral. Cleanouts will also be required within five feet upstream of every change in direction 45 degrees & greater and immediately downstream of the trap. Cleanouts shall be constructed using a one piece combination wye and eighth bend and riser to the ground surface. The riser pipe shall be provided with a standard four (4) inch screw type ferrule and shall be watertight.

Section 1018. Commercial installations must also comply with all local construction regulations.

Section 1019. All costs and expenses of the construction of a building sewer and all costs and expenses of connection of a building sewer to a sewer shall be borne by the owner of the occupied building(s) to be connected; and such owner shall indemnify and save harmless the **Borough** from all loss or damage which may be occasioned, directly or indirectly, as a result of construction of a building sewer or of connection of a building sewer to a sewer.

Section 1020. An existing building sewer that served a previously occupied building on the property may be used to serve a new occupied building that is replacing the earlier occupied building only when it is found upon examination and/or testing by the **Borough** or its authorized representative, to meet all requirements as set forth in the Rules and Regulations of the **Borough**.

Section 1021. The building sewer and the service lateral leading from the property to the interceptor or collection sewer of the **Borough** shall at all times be the responsibility of the person, firm or corporation owning the property for maintenance, repair or replacement.

Section 1022. No repairs, alterations or additions to any building connection of the sewer system shall be made unless the person desiring to make same shall first make application to and receive permission from the **Borough**.

Section 1023. No owner or tenant of any premises connected with the sewer system shall be allowed to permit any other persons or premises to use or connect with his service line except upon written permission of the **Borough**.

Section 1024. The Borough will install and maintain the service between the sewer main and the property or Borough easement line. The owner is responsible for and shall pay the costs of the proper installation and maintenance of the building connection from the end of the service lateral to the building. Each connection and/or modification to the sewer system must be made at the expense of the owner and be inspected by an authorized representative of the **Borough** before the pipe is backfilled. The owner shall certify in writing to the **Borough** that no roof, surface, foundation or underground drainage is connected to the sanitary sewer. Cellar drains not connected to an outside surface, underground, foundation or sub-basement drain may be connected to the sanitary sewer provided the cellar drain system is tested for watertightness as outlined in Article XIX. There shall be a \$25.00 charge for each re-inspection required by reason of faulty original installation and/or modification.

Section 1025. All sewers shall conform to Pennsylvania Department of Environmental Protection and the generally acceptable plumbing industry practices.

ARTICLE XI

MAINTENANCE OF LATERALS AND BUILDING SEWER

Section 1101. Notwithstanding any other provision of this Resolution, the maintenance of sewer laterals and building sewers from the collection or interceptor line of the Borough to the premises or property line of the user or customer shall at all times be the obligation of the **owner or customer and shall not be the obligation of the Borough** regardless of whether the sewer lateral has been installed by the Borough. Customer shall also be responsible for all repairs to street and/or sidewalk to the Borough of Markleysburg or PennDOT Specifications. All work shall require inspection by the Borough at the customers expense.

ARTICLE XII

PROPOSED EXTENSIONS OF SYSTEM BY DEVELOPERS

Section 1200. Developer shall be entitled to obtain preliminary review, in accordance with the provisions of the section. In order to obtain such preliminary review, Developer shall submit the following: Name of Developer; name of property owner (if different than Developer); the location of the property; size of the overall property owned by the property owner or Developer; a general sketch drawn to scale with dimensions indicated thereon showing the location of the property and the general layout of the intended development (that is to say, the location of all houses to be constructed by Developer), include on the sketch the location of roads, lot layouts, the approximate location of existing utilities, including gas, electric, water, sewers and any other utilities. Developer shall submit such information (including the sketch required hereunder) in triplicate. After receipt of such information in writing, **Borough** shall advise Developer and indicate whether or not the existing system has sufficient capacity to accommodate the development, the location of existing sanitary sewage facilities, the depth and location of existing manholes in the approximate area of the development and any other preliminary comments as the **Borough** may wish to make. The review by the **Borough** shall not in any way constitute authority for the Developer, owner or anyone else to proceed with construction or to connect to any existing lines or to the sanitary sewage system.

Section 1200A. Any developer planning an extension to the public sanitary sewage system shall strictly follow the planning procedures prescribed by the Pennsylvania Department of Environmental Protection (DEP). If required by DEP, the developer should:

- a. Obtain and prepare DEP Planning Modules for Land Development.
- b. Submit completed modules, along with completed DEP form letter of transmittal and Resolution for Plan Revision to the municipality for review and execution.
- c. After the municipality's execution, obtain letters of approval from the Borough and the municipality's Planning Commission.
- d. Submit completed modules and aforementioned letters to DEP for review and approval.

- e. If DEP approves the planning modules, the developer shall then prepare the Water Quality Management Permit (W.Q.M.P.) application and sewer modules, if required.
- f. The W.Q.M.P., sewer modules, plans and specifications shall then be submitted to the **Borough** for review and approval.
- g. If the **Borough** approves the submitted material, the W.Q.M.P. application will be executed and all documents will be forwarded to DEP by the **Borough**.
- h. After DEP's approval, the developer may initiate construction after notifying the **Borough** of start date.

Section 1201. Five (5) copies of plans for proposed extensions shall be submitted to the **Borough** on 24" x 36" sheets showing plan views to a scale of 1"=50' and profiles to a scale of 1"=10' vertically and 1"=50' horizontally, a north point, a suitable title block, date and the name of the engineer or surveyor and imprint of his registration seal.

Section 1202. All sewers shall be designed in accordance with the Sewerage Manual of the Pennsylvania Department of Environmental Protection, Division of Sanitary Engineering, and these Rules and Regulations.

Section 1203. As a condition to the approval of plans and specifications for extensions to the sewer system to be built by builders, developers or other agencies, and prior to the commencement of construction of said extension, the builders, developers or other agencies shall execute a sewer extension agreement with the **Borough** under which the owner agrees upon the completion of the extension to offer to the **Borough** a deed of dedication to the collection system to be installed, which deed shall convey all right, title and interest in the collection lines to the **Borough**, free and clear of all encumbrances and charges. The agreement to be signed in this connection shall specifically provide that in the event a deed of dedication is not offered to the **Borough**, the **Borough** shall be entitled to specific performance of the agreement and the costs of enforcing the agreement, including reasonable attorney's fees, which shall be paid by the defaulting party and shall be made a part of the order of the court in granting specific performance.

Section 1204. Construction of sewers will not be permitted until the proper State Permits have been obtained. All necessary permits shall be obtained at the expense of the developer.

Section 1205. Prior to final acceptance of any sewer extensions by the **Borough**, it will be necessary for the developer to furnish to the **Borough** "as built plans" showing the angle and distance between manholes, the top and invert elevation of each manhole and the exact location of all house sewer connections relative to the nearest manhole both downstream and upstream.

Section 1206. Easements shall be recorded in the name of the **Borough** for all sewers to be constructed outside of dedicated street rights-of-way.

Section 1207. All sewer pipe proposed by the Developer shall have prior approval

of the **Borough** before installation.

Section 1208. All sewer pipe shall be a minimum of eight (8) inches in diameter and have a minimum of laying length of not less than five (5) feet.

Section 1209. The details of any jointing connection which is proposed for use must be submitted to the **Borough** for prior approval.

Section 1210. The installation of sewers shall start at the lower end of the line and proceed upstream so that the spigot ends point in the direction of flow. The pipe shall be carefully laid to line and grade. The handling, placing and jointing of pipe shall be in strict accordance with the pipe manufacturer's recommendations.

Section 1211. All manholes shall be constructed in accordance with the standards established by the **Borough**. Frames and covers for all manholes shall be fabricated of cast iron and shall conform to the standards established by the **Borough**. Vented covers shall be furnished at the ends of lines. Precast concrete manhole sections shall conform to the standards established by the **Borough**. Where determined necessary by the **Borough**, the developer shall incorporate the use of grease traps in the sewer connection plans before approval is given.

Section 1212. Sewers shall be hydrostatically, pneumatically, smoke tested, televised or tested by other means as determined by the **Borough** for leakage at the discretion of, and in the manner required by, the **Borough**. Testing shall be done at the developer's expense, and an agent of the **Borough** shall be present when all testing is being done.

Section 1213. The Developer shall file all necessary connection permits and pay the applicable tap connection and inspection fees for each house or building to the **Borough** which shall become due and payable prior to inspection and approval by the Inspector for each respective house service sewer.

Section 1214. The developer shall also reimburse the **Borough** in full for all costs of Engineer's plan review and of inspection of construction of all sanitary sewers. The amount and type of inspection required shall be determined by the **Borough** during construction. Prior to performing any work, the developer shall establish an escrow account at an institution agreeable to both the **Borough** and developer. Said escrow account shall be in the name of the **Borough** to be used for paying engineering, legal and inspection fees incurred. The escrow amount to be deposited shall be determined by the **Borough**. Upon acceptance of the developer's project by the **Borough**, or project termination, the balance of funds in the escrow account, including accrued interest, will be refunded to the developer.

Section 1215. No sewer extensions constructed by a Developer will be approved for use and acceptance by the **Borough** until said sewers are formally approved by the **Borough**, all building tap connection and inspection fees have been paid for each building connected to the system, and the **Borough** has been reimbursed in full for all inspection costs incurred by the Inspector during construction, testing and approval.

Section 1216. The cost and expense of any such extensions, subject to the approval and compliance with the rules and regulations hereunder, shall be borne by the Developer, and costs shall include, but shall not be necessarily limited to the cost of acquisition of rights-of-way (whether as compensation for the right-of-way expenses or other expenses in connection therewith) or for the construction and extension of the system and shall further include a charge in the amount of the actual costs of review and examination by the **Borough's** engineer payable to the **Borough** as compensation for the review and examination of plans to be submitted hereunder.

Section 1217. Whenever sewers are installed by persons, firms or corporations other than the **Borough**, the installation and materials shall be made and furnished in accord with the **Borough's** standard construction specifications and in accordance with the rules and regulations of the **Borough**. In the event that the person, firm or corporation installing a sewer extension fails to comply with the requirements of the **Borough**, the **Borough** shall give notice in writing of such non-compliance; and in the event that the person, firm or corporation so installing the extension shall fail to replace or repair the installation with respect to which notice of non-compliance has been received, the **Borough** may take whatever measures are necessary to conform the installation to the requirements of the **Borough** at the costs and expense of the owners, together with 10 percent (10%) additional thereof and all charges and expenses incidental thereto, which sum shall be collected from said owner or owners for the use of the **Borough** as debts are by now collectible.

Section 1218. In the event that a Developer shall wish to extend a house service line to service an individual house (which service line may under applicable Rules and Regulations of the **Borough** be constructed of sewer pipe of a minimum of eight (8) inches in diameter) the **Borough** may require the Developer to construct and establish a sewer line meeting all the requirements of this Article XII if the **Borough** shall determine that there shall exist the possibilities that there may be further extensions of this system in the area of such house service line. In such event, the **Borough** shall compensate the Developer for the difference of cost only as between sewer pipe six (6) inches in diameter and sewer pipe eight (8) inches in diameter. All other expenses shall be and remain the sole and complete obligation of the Developer.

ARTICLE XIII

CONNECTION OF EXISTING SEWAGE COLLECTION SYSTEMS

Section 1301. The owner or owners of any existing sewage collection system within the **Borough's** service area upon premises accessible to the public sanitary sewage system shall, at their own expense, make connection with the public sanitary sewage system in accordance with the applicable Connection Ordinance in effect in the **Borough's** service area and the **Borough's** Rules and Regulations.

Section 1302. The owner or owners of any existing sewage collection system within the **Borough's** service area located upon premises accessible to the public sanitary sewage system shall make application for connection to the public sanitary sewage system to the **Borough** upon the permit form to be formulated and furnished by the **Borough**.

Section 1303. All information requested on said form shall be furnished by the applicant, including the character and use of each structure located upon the property or properties.

Section 1304. At the time of application and prior to final acceptance of any existing sewage collection system by the **Borough**, it will be necessary for the owner or owners to furnish to the **Borough** "as built plans" showing information such as the angle and distance between manholes, the top and invert elevation of each manhole and the exact location of all connections to the sewer system relative to the nearest manhole both upstream and downstream, and any other supporting documentation as required by the **Borough**.

Section 1305. As a condition to the approval of the **Borough** for connection of the existing sewage collection system to the **Borough's** sewer system, the owner or owners of said system shall execute an agreement with the **Borough** under which the owner agrees to offer to the **Borough** a deed of dedication to the collection system, which deed shall convey all right, title, and interest in the collection lines to the **Borough**, free and clear of all encumbrances and charges.

Section 1306. At the time of application and prior to acceptance of any existing sewage collection by the **Borough**, the sewers shall be tested by any of the following methods or combinations of methods, including hydrostatic testing, pneumatic testing, smoke testing, televising or testing by any other means as determined by the **Borough** for the purposes of determining infiltration, inflow and/or the condition of the existing sewers, at the discretion of, and in the manner required by the **Borough**. All testing shall be done at the owner's expense.

Section 1307. Any required tap connection and inspection fees shall be paid at the time of making application for permission to connect the existing sewage collection system to the public sanitary sewage system.

Section 1308. Upon receipt of a properly completed application for connection to the public sanitary sewage system, accompanied by any required tap connection and inspection fees, the **Borough** shall review the application and any related supporting documentation as required by the **Borough** prior to issuance of a sewer connection permit.

Section 1309. Upon completion of the application review, the **Borough** will notify in writing the owner or owners of the existing sewage collection system whose application was reviewed of the **Borough's** decision on the sewer connection permit. If the permit is denied, the **Borough** will justify its denial in writing.

Section 1310. Upon denial of a sewer connection permit for an existing sewage collection system, the owner or owners of the collection system shall meet with the **Borough** to determine a Plan of Corrective Action and a timetable to address the reasons for which the permit was denied. The Plan of Corrective Action will be formally submitted to the **Borough** within thirty (30) days of the above-referenced meeting.

Section 1311. Upon completion of the Plan of Corrective Action, the review of the application for connection of the existing sewage collection system to the public sanitary sewage system will be reopened.

Section 1312. No work shall commence before payment of any aforementioned tap connection and inspection fees and issuance of the aforementioned sewer connection permit.

Section 1313. The connection of the existing sewage collection system to the public sanitary sewage system shall be subject to certain restrictions as to unacceptable sanitary sewage which are set forth herein in Article V and shall be subject to all other applicable provisions of these Rules and Regulations as established herein and amended from time to time.

Section 1314. The designated Inspector of the **Borough** shall be given at least twenty-four (24) hours notice of the time when such connection shall be made in order that said Inspector can be present to inspect and approve the work of connection. The Inspector shall signify his approval of the connection by endorsing his name and the date of approval on the aforementioned connection permit in the possession of the permittees.

Section 1315. At the time of inspection of the connection, the owner or owners of properties shall permit the Inspector full and complete access to all sanitary and drainage arrangements and facilities in each building and in and about all parts of the property. The connecting sewer line shall not be covered over, or in any manner concealed, until after it is inspected and approved by said Inspector.

Section 1316. It is the intention of these Rules and Regulations that the entire connection be inspected at one time; however, if the property owner feels that special conditions warrant more than one inspection, he may request the same, subject to such additional inspection fees as the **Borough** shall determine.

Section 1317. Use of a new connection to the sewer system will not be permitted until the installation has been inspected and approved in accordance with the **Borough's** procedures.

Section 1318. All sewer pipe, fittings, and joints in the existing sewage collection system and the proposed connecting sewer line shall be of a material and type approved by the **Borough** and the **Borough's** engineer, with a minimum diameter of eight (8) inches.

Section 1319. All manholes in the existing sewage collection system and the proposed connecting sewer line shall be of a type and a material meeting the standards established by the **Borough**.

Section 1320. Easements shall be recorded in the name of the **Borough** for all sewers constructed outside of dedicated street rights-of-way.

Section 1321. All costs and expenses associated with the connection of an existing sewage collection system to the public sanitary sewage system shall be borne by the owner or owners of said system and shall also include a charge in the amount of the actual costs of review and examination by the **Borough's** engineer of the existing collection system as requested by the **Borough**.

ARTICLE XIV

PROPOSED INDIVIDUAL HOUSE SERVICE PUMP INSTALLATIONS

Section 1401. Where owner or owners of property are unable to make connections from their principal building to the sanitary sewer by a gravity service lateral as previously described, the owner or owners shall install an individual house service pump, as approved by the **Borough** and hereafter described. Refer to plates XIV and XV for typical installation.

Section 1402. The grinder pump unit shall be capable of reducing any material in the wastewater which enters the grinder unit to such size that the material will pass through the pump unit and pressure sewer without plugging or clogging. No screens or other devices requiring regular maintenance shall be used to prevent trashy material from the grinder pump.

Section 1403. Pump shall have a minimum capacity of 8 GPM. Total pump discharge head will depend on each individual installation. Pump motor shall be minimum 1 HP, 1 phase power.

Section 1404. Appropriate high water and overflow detection devices (alarm light) shall be provided. Alarm light shall be supplied in a separate enclosure for monitoring outside the principal building and to be visible from the front, or roadside.

Section 1405. The minimum net storage capacity of the grinder pump unit shall be approximately 50 gallons. The grinder pump tank should be able to accommodate normal peak flows and emergency storage during a short power failure.

Section 1406. The grinder pump shall have the characteristics which will continue to produce flows of at least 8 gpm even when conditions in the pressure system cause heads to rise temporarily to values higher than the normal maximum.

Section 1407. Check and shut-off valves shall be employed to isolate the grinder pump unit from the house service line and the pressure laterals.

Section 1408. Provisions shall be made to insure that the grinder pump operates even under temporary loads above normal and contains integral protection against back siphonage and over pressure.

Section 1409. If the grinder pump unit is installed outside the residence, provision must be made for access, as well as protection from weather and vandalism. Inside installations shall be quiet and free from electrical and/or health hazards and (shall) preferably be certified by nationally recognized independent testing laboratories, such as the Underwriter's Laboratories, Inc. and the national Sanitation Foundation. The grinder pump unit must be capable of being removed without dewatering the collection tank.

Section 1410. The sump basin may be of concrete, 1/4" thick steel, or fiberglass construction. Basin, if steel, and cover shall be sandblasted inside and outside to remove scale, slag, rust, etc. before painting. Basin, if steel, shall be coated inside and outside with tar base epoxy paint for corrosion resistance.

Section 1411. No pressure sewer lateral less than 1¼" inside diameter shall be provided. The required size shall be determined to maintain low frictional losses in the system and a minimum scouring velocity of 2 feet per second. The pressure sewer piping shall be installed with a minimum 42" depth of cover to protect against freezing and damage from vehicular traffic. PVC SDR-21 pipe or PVC Schedule 40 pipe shall be used. Bedding and backfill procedures shall be as described in previous sections for gravity sewer laterals. Pressure sewer piping shall be color coded (brown) to distinguish the piping from water service lines.

Section 1412. Grinder pump units must be serviceable and replaceable under wet conditions without electric hazard to the repair personnel.

Section 1413. The Homeowner's obligations are as follows:

- a. Purchase and installation of grinder pump unit and pressure piping to the gravity sanitary sewer or force main.
- b. Provide repairs, normal maintenance and care as unit manufacturer and Borough recommends.
- c. Pay for the cost of installation and the cost of electricity.
- d. Pay for the cost of future grinder pump replacement if damaged.
- e. Homeowner agrees to allow either a representative of the Borough or designated maintenance person access to the homeowner's property.

Section 1414. The **Borough's** obligations are as follows:

- a. Approval of homeowner's proposal for pump unit and pressure piping design.
- b. Inspection of pump unit and pressure piping installation.
- c. To inspect and determine repairs or maintenance required for the grinder pump unit one (1) time per year.

Section 1415. The only exception to this installation and maintenance requirement applies to grinder pump units included in the original design of the **Boroughs** sewage system. The **Borough** will own and maintain the grinder pump units included in the original design and installed under contract "03-S-03 Sanitary Sewers".

ARTICLE XV

DELINQUENCIES, VIOLATIONS AND REMEDIES

Section 1501. Each sewage collection, transportation and treatment charge, surcharge and penalty imposed by the Sewer Rate Resolution of the **Borough** shall be a debt due the **Borough** and shall be a lien on the property served, and if not paid within the period prescribed in the Sewer Rate Resolution after the date of the bill shall be deemed delinquent. In such event, the **Borough** shall proceed to file a lien in the office of the Prothonotary of Fayette County and collect the same in the manner provided by law for the filing and collection of municipal claims. In the event of failure to pay the sewage collection, transportation and treatment charge or surcharge or penalty after they become delinquent, the **Borough** may also authorize the appropriate personnel to shut off water service to said property or to remove or close the sewer connection and to take such steps as may be necessary to accomplish such shut off or removal or closing. The expense of such shut-off or removal or closing, as well as the expense of restoring any such service, shall likewise be a debt due the **Borough** and a lien on the property served and may be filed and collected as hereinabove provided. Such sewage service shall not be restored until all sewage collection, transportation and treatment charges, surcharges and penalties, including the expense of removal, closing and restoration shall have been paid or adequate provisions for their payment shall have been made.

Section 1502. All persons violating any provisions of these Rules and Regulations shall be given notice of such violation either personally or by means of the United States mails, and if no action to correct said violation is taken within thirty (30) days of the date of such notice, water to said premises may be shut off or the sewer connection may be removed or closed. Reconnection will not be made until after correction of the violation has been accomplished. The expense of such shut-off or removal or closing and the expense of restoring the water or sewage service shall be a debt due the **Borough** and a lien upon the property served and may be filed and collected as provided in Section 1501 hereof.

ARTICLE XVI

INSPECTION BY THE BOROUGH

Section 1601. For the purpose of enforcing the Rules and Regulations of the **Borough** with respect to the operation of the sewer system and for the purpose of advancing and protecting the public health, the **Borough** reserves the right to enter upon the premises of any person, firm or corporation connected to the system for the purpose of inspecting the sewer facilities located thereon and for the purpose of determining compliance with the requirements of the **Borough**. Duly authorized employees of the **Borough** shall be permitted to enter all properties for the purpose of inspection, observation, measurement, sampling, and testing in accordance with the provisions of these Rules and Regulations. In the event that the **Borough's** duly authorized representatives are denied access to any customer's premises for these purposes, the **Borough** reserves the right to discontinue sewer service to such premises until inspection is permitted and compliance with the requirements of the **Borough** has been determined.

ARTICLE XVII

VALIDITY

Section 1701. If any one or more of the provisions of this set of Rules and Regulations shall for any reasons be held to be illegal or invalid or otherwise contrary to law, then such provisions shall be null and void and shall be deemed separable from the remaining provisions hereof, but shall in no way otherwise affect the validity of these Rules and Regulations.

Section 1702. These Rules and Regulations shall take effect immediately.

Section 1703. All other rules and regulations affecting the Sewer System not in accordance with these Rules and Regulations are hereby repealed insofar as they affect these Rules and Regulations.

Section 1704. These Rules and Regulations were adopted pursuant to and in accordance with a Resolution of the **Borough**.

ARTICLE XVIII

STANDARD DETAILS

Section 1801. Appended to these Rules and Regulations is a listing of Standard Details that shall be used in the construction of the sanitary sewers and appurtenances described herein.

ARTICLE XIX

TESTING

Section 1901. All prospective sewer customers wishing to connect to the **Borough's** sanitary sewer system shall demonstrate, to the **Borough's** satisfaction, that all buried sewer piping intended to be connected to the **Borough's** facilities is in a watertight condition, by performing either of the testing methods described later herein and such testing must be witnessed and approved by the **Borough** Inspector prior to the final connection of the customer sewer piping to the **Borough's** sewer facilities.

Section 1902. Prospective customers must first pay all applicable sewage fees and charges. Said customers must, prior to inspection and testing, provide a plumbing diagram (on the **Borough's** form) showing the piping layout of all buried sewer piping, including such piping buried below basement floor level. The plumbing diagram must note the pipe size, material and lengths of pipe between fittings.

Section 1903. All piping installed outside of the building foundation must be inspected, tested and approved by a **Borough** Inspector for compliance with installation standards of the **Borough**.

However, all buried (or to be buried) sewer piping, both outside and inside the foundation wall must be tested for water tightness and such testing be witnessed and approved by the **Borough** Inspector.

Section 1904. It is suggested that the piping system be tested before any backfilling and certainly before pouring of the concrete floor. Testing of the inside piping may be performed separate from the outside sewer inspection testing, at the applicant's option. However, it may be more convenient for the customer to combine the outside inspection testing and inside testing of the entire buried piping into one operation.

Section 1905. Requests for inspection (of the outside sewer lateral installation) and/or witnessing of the testing (of the outside lateral and/or inside piping) must be made a minimum of twenty-four (24) hours in advance of the requested time. At or prior to such requests, the applicant must provide the aforementioned completed plumbing diagram form to the **Borough**.

Section 1906. Acceptable testing methods include: a). Testing by smoke: b). Testing by dye: c). Testing by water, wherein all buried piping is filled with water and a temporary water column introduces a minimum of ten (10) feet of head to the highest portion of the buried piping, with no water loss observed during a fifteen (15) minute period, and: d). Testing by air, wherein all buried piping is pressurized with air to a minimum of 5 psi (5 pounds per square inch) and thereafter held for fifteen (15) minutes with testing can be found in the BOCA National Plumbing Code (1990 ed.) Article 17 or the CABO One and Two Family Dwelling Code (1995 ed.), Chapter 29 as may from time to time be amended.

Section 1907. All work necessary to provide for and perform such testing shall be the responsibility of the Applicant. The **Borough's** Inspector shall only witness such testing and make the determination as to correct testing procedures and the results of such testing, pass or failure. The Applicant shall provide clean and safe access to the location where the testing observation is conducted (to view the top of the 10' water column or to view the air pressure gauge).

Section 1908. The **Borough** Inspector shall make the sole determination as to when the actual testing period commences, and thereafter expires after 15 minutes duration. Upon successful completion of the testing, the inspector shall signify his/her approval by affixing their signature and dating the completed Sewer Inspection Form, a copy of which shall be provided to the Applicant or their designated agent. Upon receipt of the approved Sewer Inspection Form, the Applicant must complete the connection of the privately owned piping to the **Borough's** sewer piping. No such connection is allowed until the Applicant has secured the approved Sewer Inspection Form.

Section 1909. In the event the testing fails to meet the stated requirements, the Inspector will affix their signature and note the time and date of such failed testing on the Sewer Inspection Form. No copy will be provided to the Applicant until such subsequent testing produces an acceptable test result.

Section 1910. All subsequent re-tests shall follow the same 24 hour notice requirements, but must also be accompanied by prepayment of the estimated inspection witnessing charge. Said charge to be computed at costs plus overhead for the time involved, including travel, for the Inspector to conduct such subsequent Inspector/witnessing.

Section 1911. After receipt of the approved Sewer Inspection Form, no alteration, addition or connection to the sewer piping so tested and approved may be without prior notice to the **Borough** and without subsequent testing/witnessing in accordance with the same requirements described above.

Section 1912. The property owner, at the time of testing, is the ultimate responsible party for the installation and subsequent inspection and testing as required by the **Borough** of an approved sanitary sewer drainage system.

ARTICLE XX

SEWAGE FACILITIES RESTRICTIONS

Section 2000. No person shall adjust, fill, bury damage, loosen, open or enter into, or lower any sanitary manhole, or cause water to flow over or into any sanitary manhole. No person shall fill over or build on any right-of-way without written permission from the Borough of Markleysburg, nor shall any person dig in any sanitary right-of-way without prior notification and approval of the Borough of Markleysburg.

Sewer System

STANDARD DETAILS

| <u>Plate No.</u> | <u>Typical Detail Description</u> |
|------------------|--|
| I | Standard Service Connection to Sanitary Sewer |
| II | Standard Service Connection from Existing Installation |
| III | Pipe Bedding |
| IV | Precast Manhole |
| V | Grease Trap |
| VI | Precast Shallow Manhole |
| VII | Watertight Manhole Frame and Cover |
| VIII | Standard Manhole Frame and Cover |
| IX | Sewer Saddle Connection to Existing Sewer |
| X | Manhole Channel Orientation |
| XI | Drop Connection to Standard Manhole |
| XII | Standard Clean-Out |
| XIII | Sewer Saddle Connection to New Sewer |
| XIV | Out-of-Door Grinder Pump Installation |
| XV | Out-of-Door Grinder Pump Installation |
| XVI | Grinder Pump Discharge Connection to Gravity Sewer |
| XVII | Grinder Pump Discharge Connection to a Pressure Sewer Force Main |

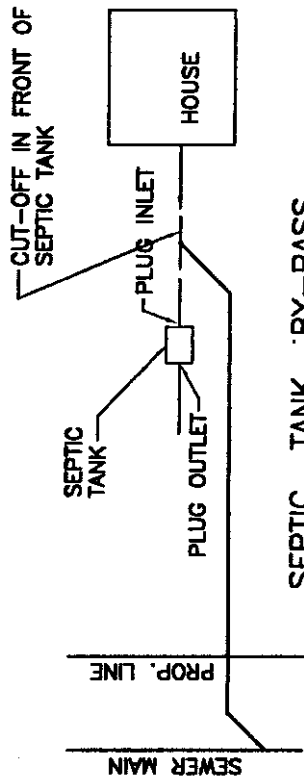

SEPTIC TANK BY-PASS

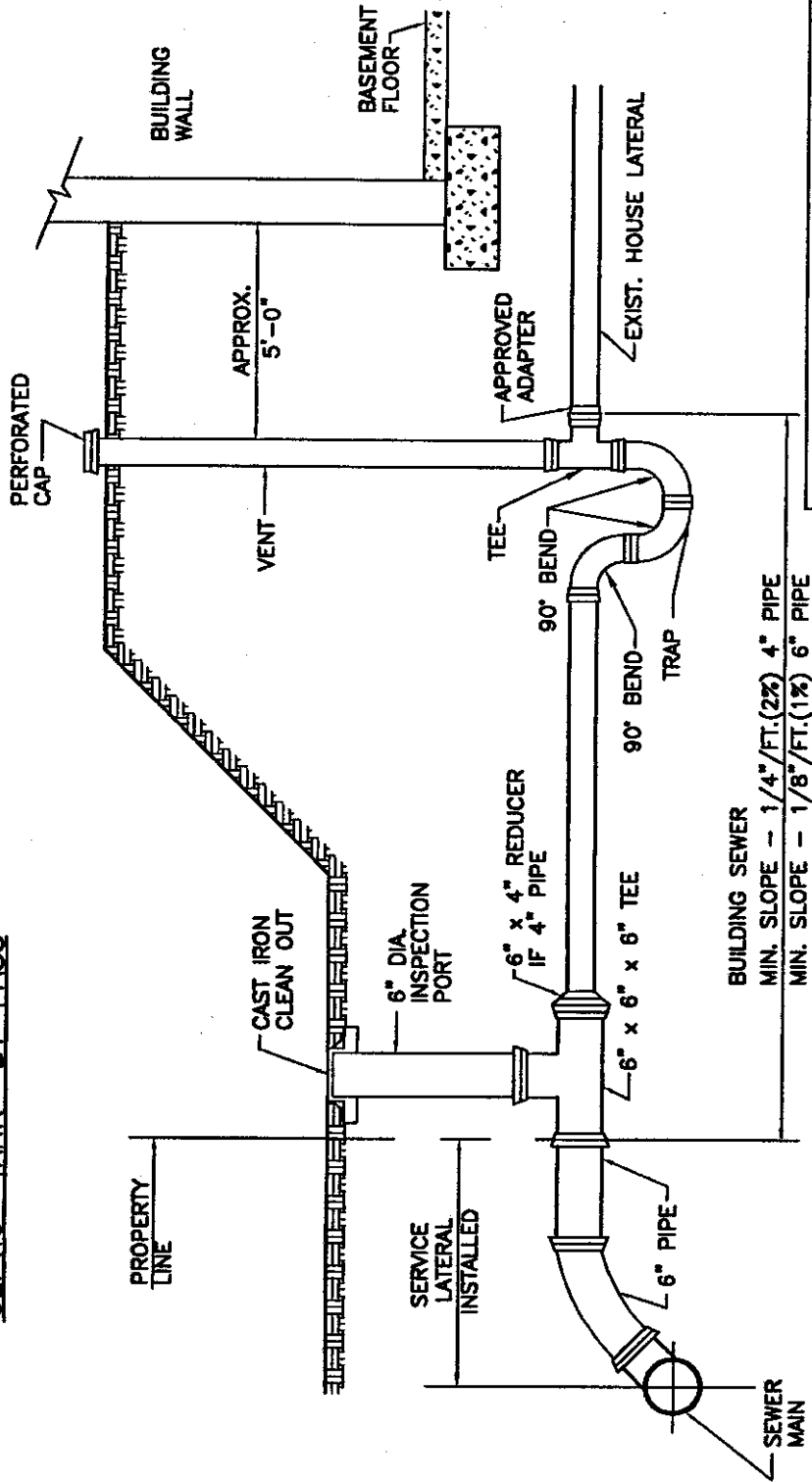

TYPICAL DETAIL

**SERVICE CONNECTION TO
SANITARY SEWER**

TYPICAL SEWER CONNECTION
N.T.S.

MARKELYSBURG BOROUGH

PLATE 1

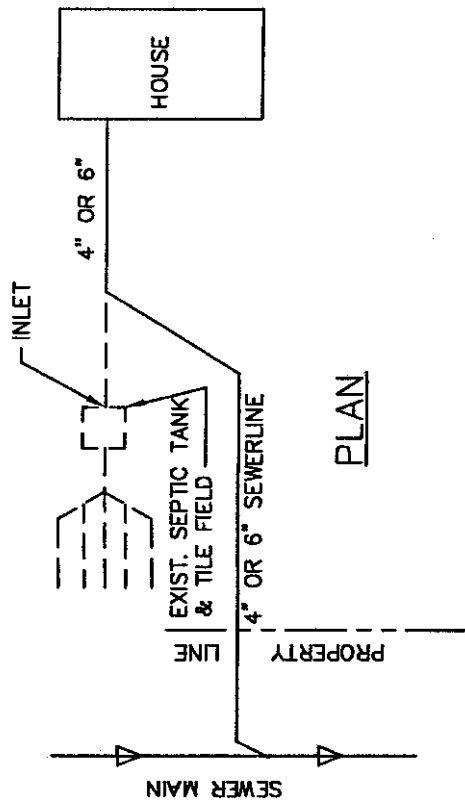

PLAN

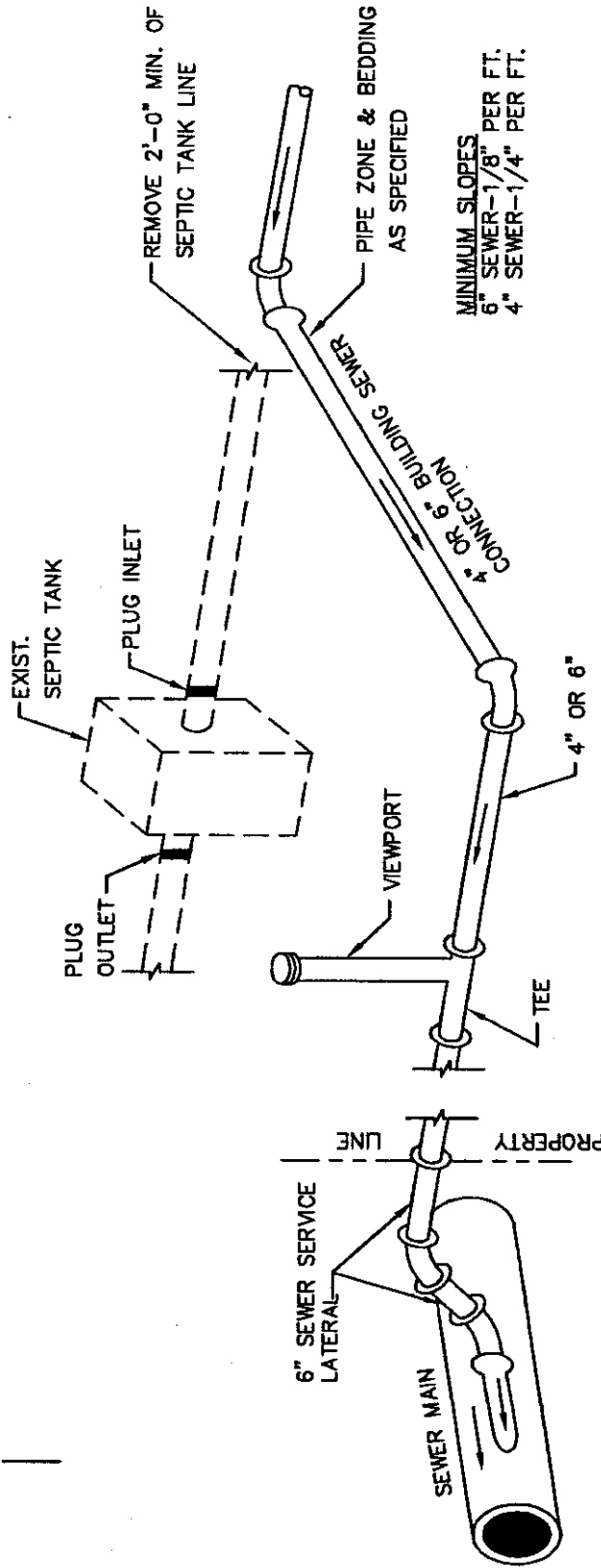

ISOMETRIC SECTION
NTS.

TYPICAL DETAIL

BUILDING SEWER CONNECTION
INSTALLATION TO BYPASS EXISTING
SEPTIC TANK

MARKELYSBURG BOROUGH

PLATE II

MINIMUM SLOPES
6" SEWER - 1/8" PER FT.
4" SEWER - 1/4" PER FT.

REMOVE 2'-0" MIN. OF
SEPTIC TANK LINE

PIPE ZONE & BEDDING
AS SPECIFIED

4" OR 6" BUILDING SEWER
CONNECTION

4" OR 6"

TEE

VIEWPORT

EXIST.
SEPTIC TANK

PLUG INLET

PLUG
OUTLET

PROPERTY
LINE

6" SEWER SERVICE
LATERAL

SEWER MAIN

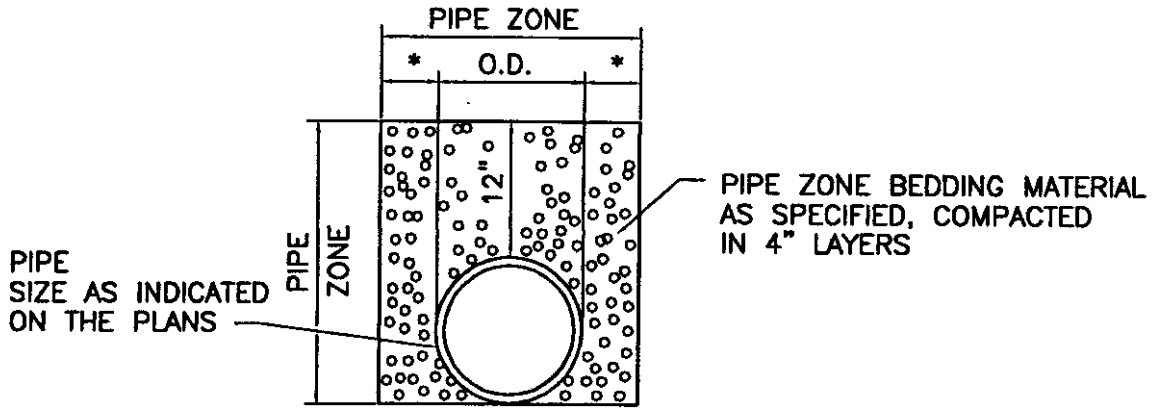

DUCTILE IRON PIPE

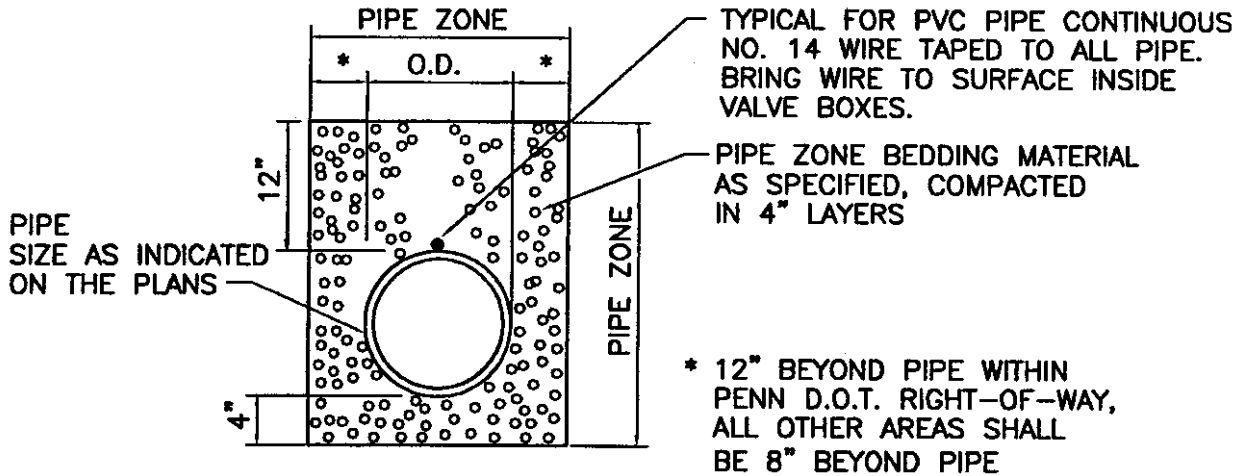

PVC PIPE

PIPE BEDDING
N.T.S.

| | |
|----------------------|-----------|
| TYPICAL DETAIL | |
| <u>PIPE BEDDING</u> | |
| MARKELYSBURG BOROUGH | PLATE III |

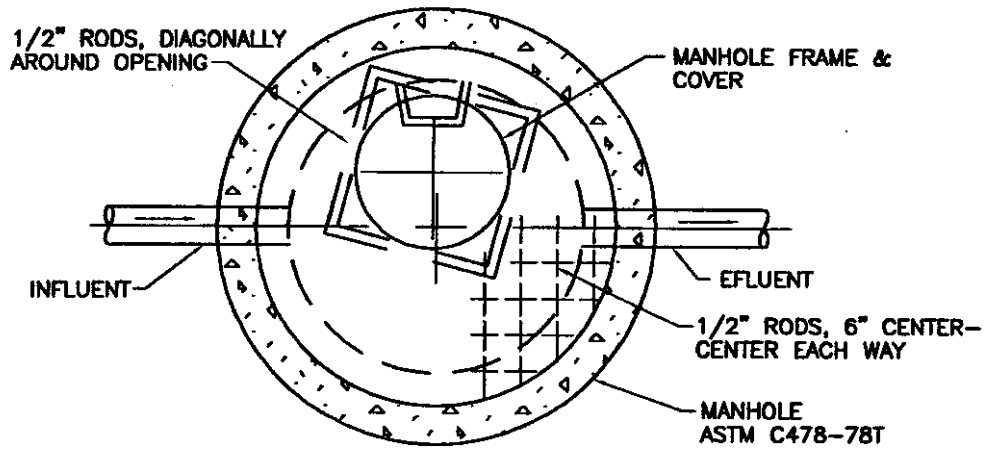

TOP VIEW

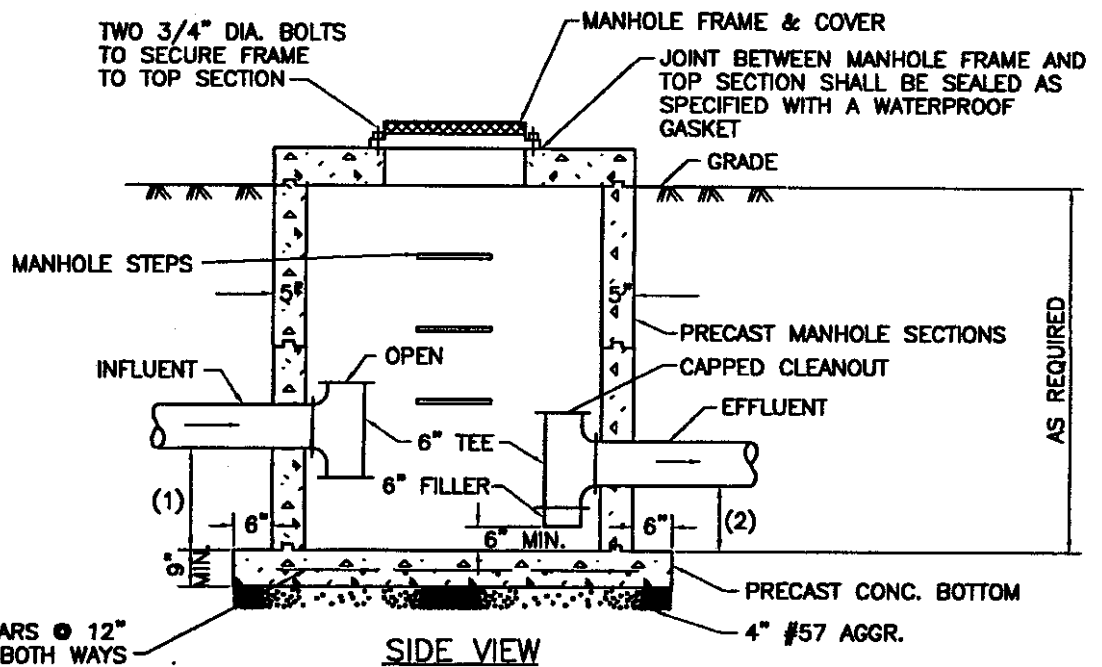

SIDE VIEW

4' DIA. M.H. GREASE TRAP CAPACITY

| | | |
|-------------|---------|---------|
| 100 GALLONS | (1)=15" | (2)=12" |
| 200 GALLONS | (1)=27" | (2)=24" |
| 300 GALLONS | (1)=39" | (2)=36" |

GREASE TRAP

N.T.S.

5' DIA. M.H. GREASE TRAP CAPACITY

| | | |
|-------------|---------|---------|
| 100 GALLONS | (1)=11" | (2)=08" |
| 200 GALLONS | (1)=19" | (2)=16" |
| 300 GALLONS | (1)=27" | (2)=24" |
| 400 GALLONS | (1)=35" | (2)=32" |
| 500 GALLONS | (1)=43" | (2)=40" |

| | |
|----------------------|---------|
| TYPICAL DETAIL | |
| <u>GREASE TRAP</u> | |
| MARKELYSBURG BOROUGH | PLATE V |

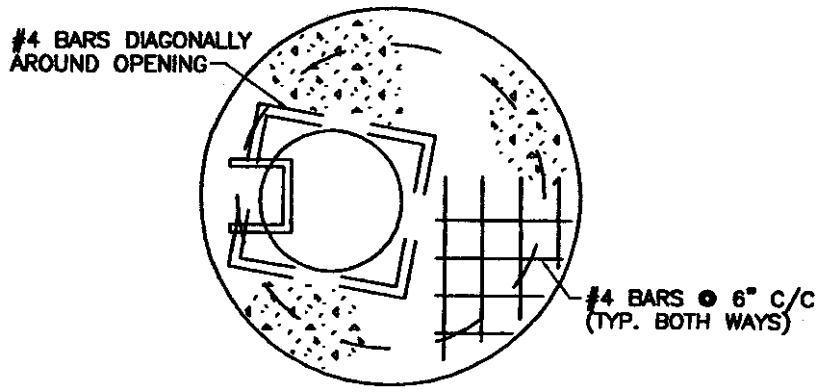

PLAN

JOINT BETWEEN MANHOLE FRAME AND TOP SECTION SHALL BE SEALED AS SPECIFIED WITH A WATERPROOF GASKET

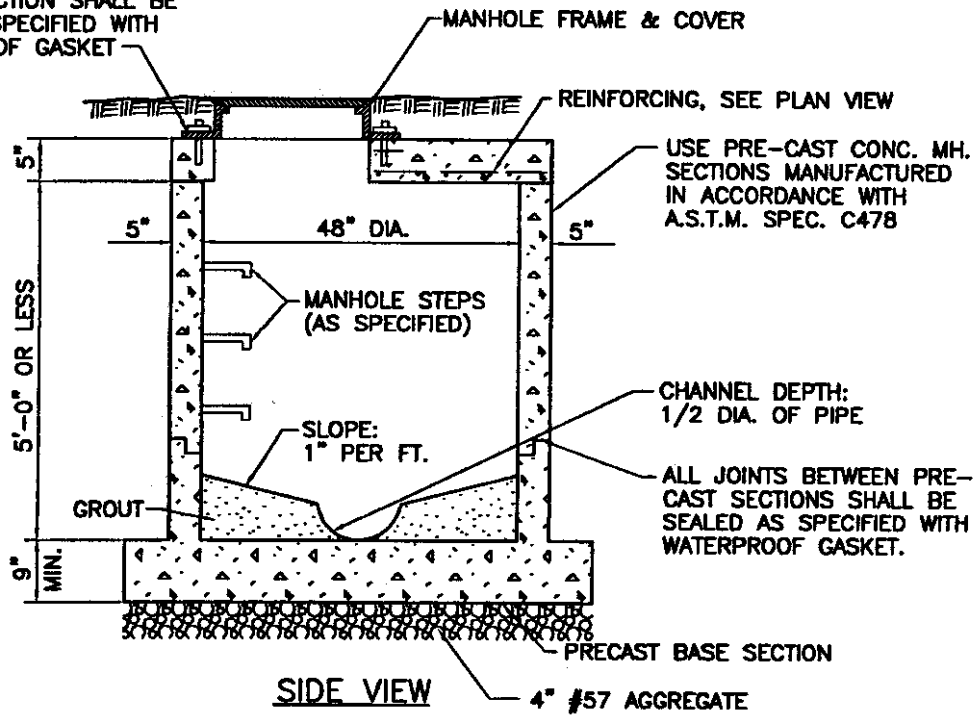

SIDE VIEW

PRE-CAST SHALLOW MANHOLE

N.T.S.

| | |
|---------------------------------|----------|
| TYPICAL DETAIL | |
| <u>PRE-CAST SHALLOW MANHOLE</u> | |
| MARKELYSBURG BOROUGH | PLATE VI |

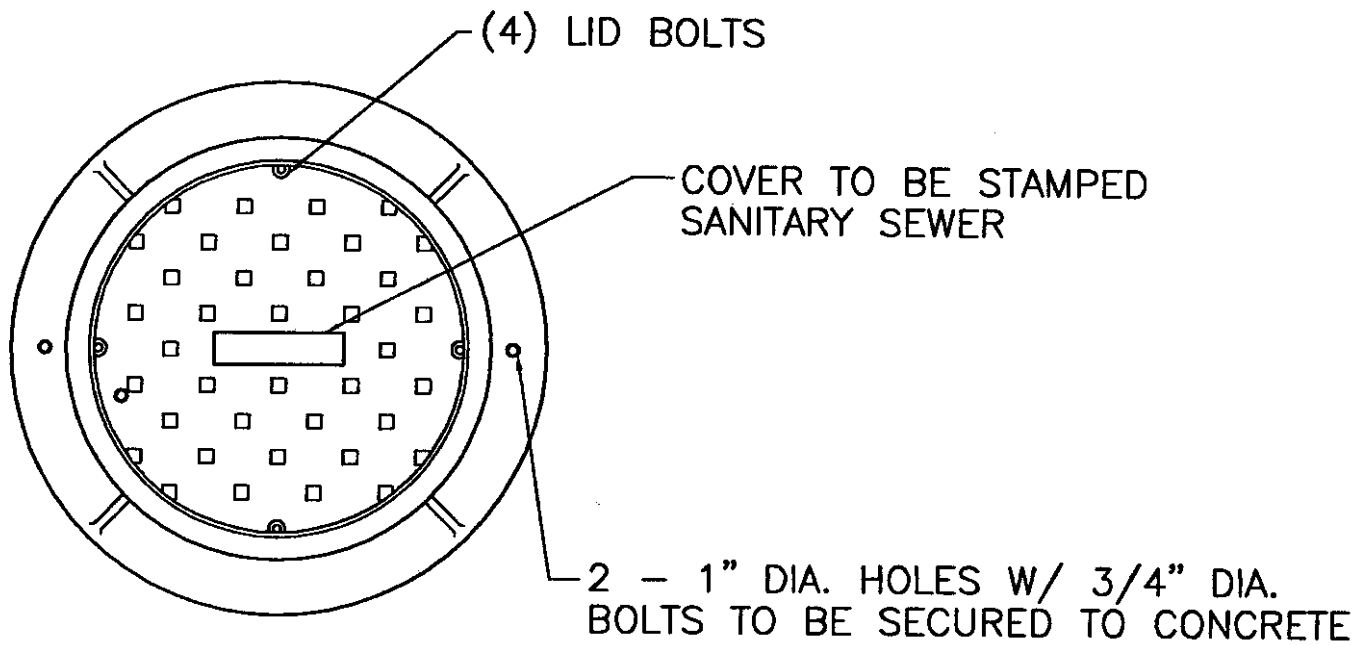

TOP VIEW

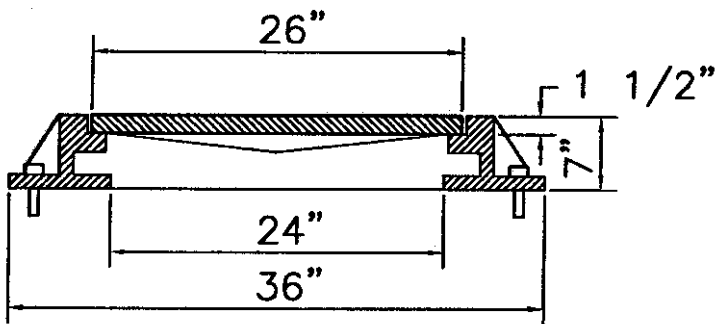

SECTION

WATERTIGHT MANHOLE
FRAME AND COVER
N.T.S.

- NOTE: 1. NEENAH SERIES R-1916-F DIMENSIONS ARE SHOWN.
2. WATERPROOF GASKET TO BE INSTALLED BETWEEN FRAME AND CONCRETE SURFACE.

TYPICAL DETAIL

WATERTIGHT MANHOLE
FRAME AND COVER

MARKELYSBURG BOROUGH

PLATE

VII

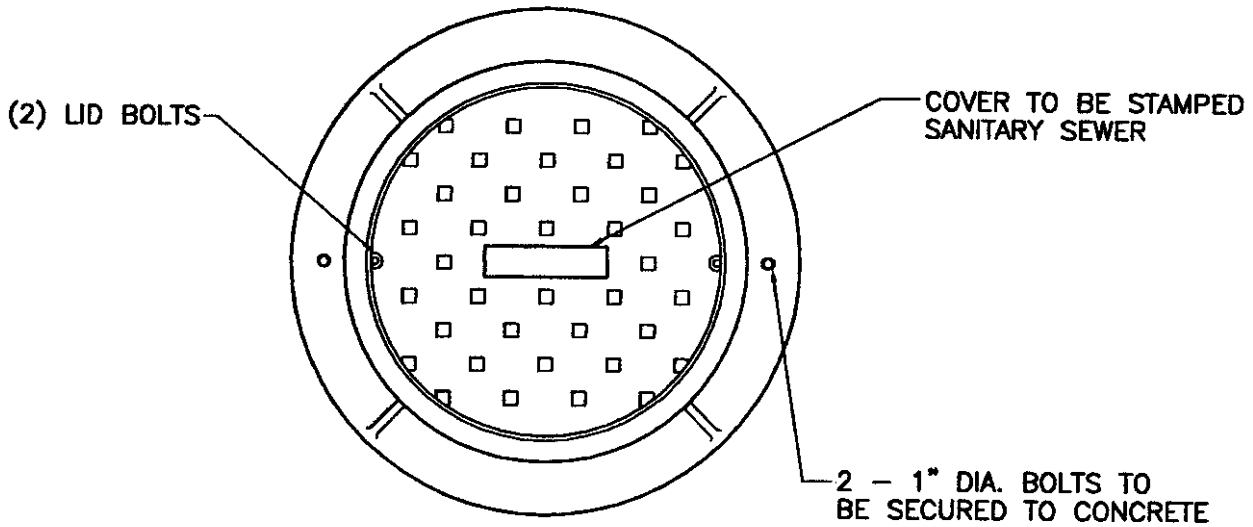

TOP VIEW

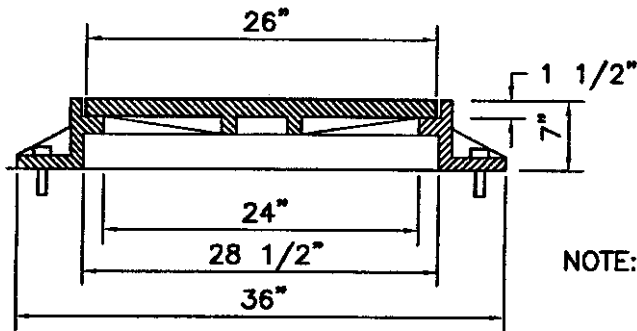

SECTION

- NOTE: 1. NEENAH SERIES R-1642
DIMENSIONS ARE SHOWN.
2. WATERPROOF GASKET TO BE
INSTALLED BETWEEN FRAME
AND CONCRETE SURFACE.

STANDARD MANHOLE
FRAME AND COVER

N.T.S.

| | |
|---|------------|
| TYPICAL DETAIL | |
| <u>STANDARD MANHOLE FRAME AND COVER</u> | |
| MARKELYSBURG BOROUGH | PLATE VIII |

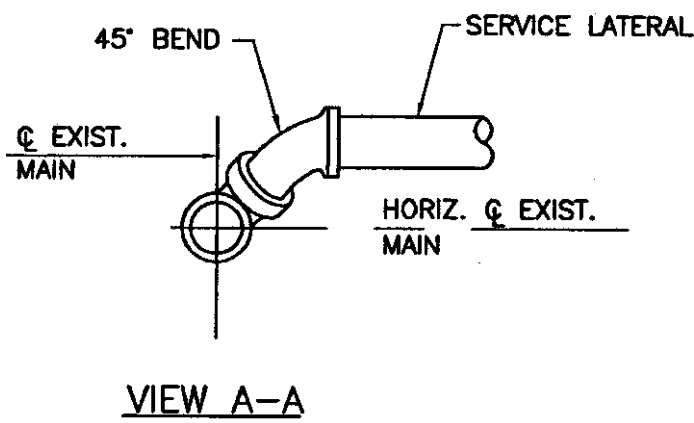
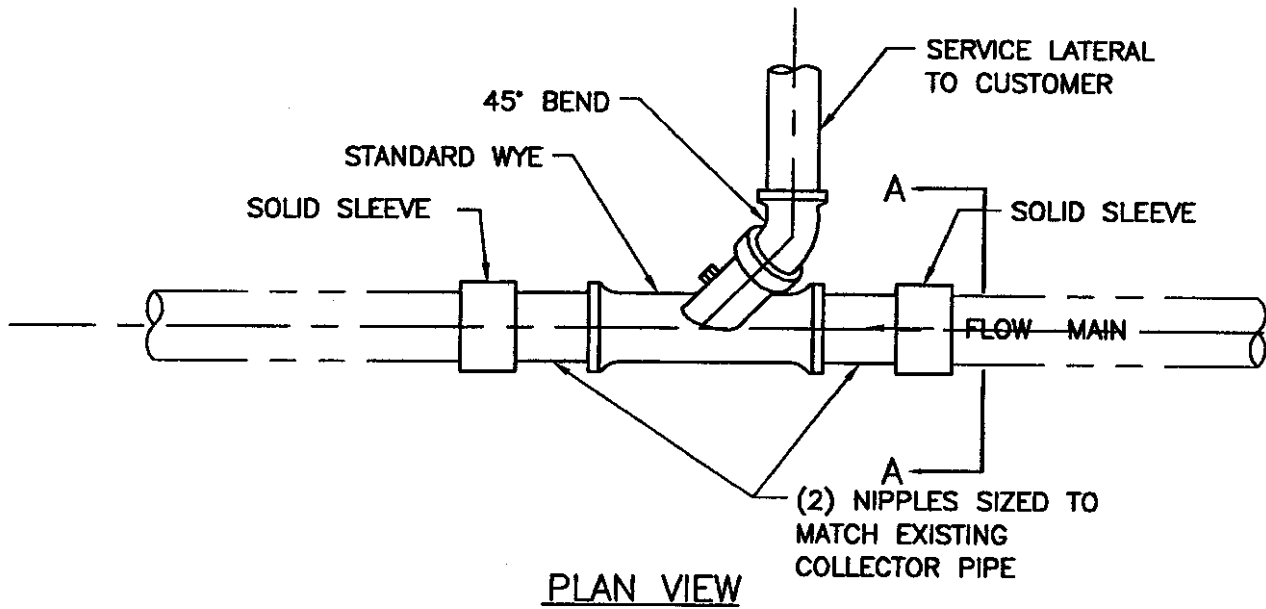

NOTES:

1. CARE SHOULD BE TAKEN NOT TO LET ANY DEBRIS ENTER THE SYSTEM WHEN INSTALLING THE NEW FACILITIES.
2. PROPER ALIGNMENT OF COLLECTION MAIN TO BE MAINTAINED.

| | |
|--|----------|
| TYPICAL DETAIL | |
| SEWER SADDLE CONNECTION TO EXISTING COLLECTOR SEWER | |
| MARKELYSBURG BOROUGH | PLATE IX |

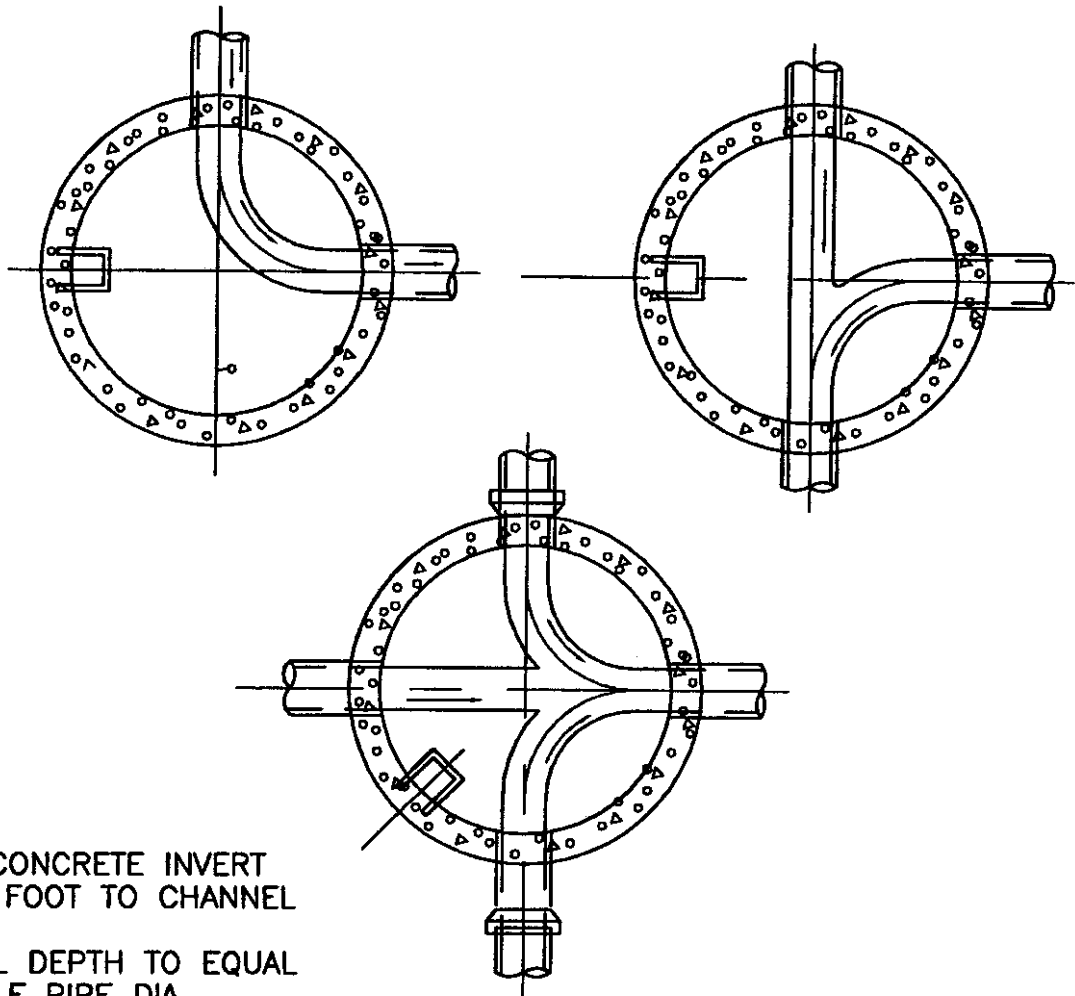

NOTES:

1. SLOPE CONCRETE INVERT
1" PER FOOT TO CHANNEL
2. CHANNEL DEPTH TO EQUAL
ONE HALF PIPE DIA.

MANHOLE CHANNEL ORIENTATION
N.T.S.

| | |
|------------------------------------|---------|
| TYPICAL DETAIL | |
| <u>MANHOLE CHANNEL ORIENTATION</u> | |
| MARKELYSBURG BOROUGH | PLATE X |

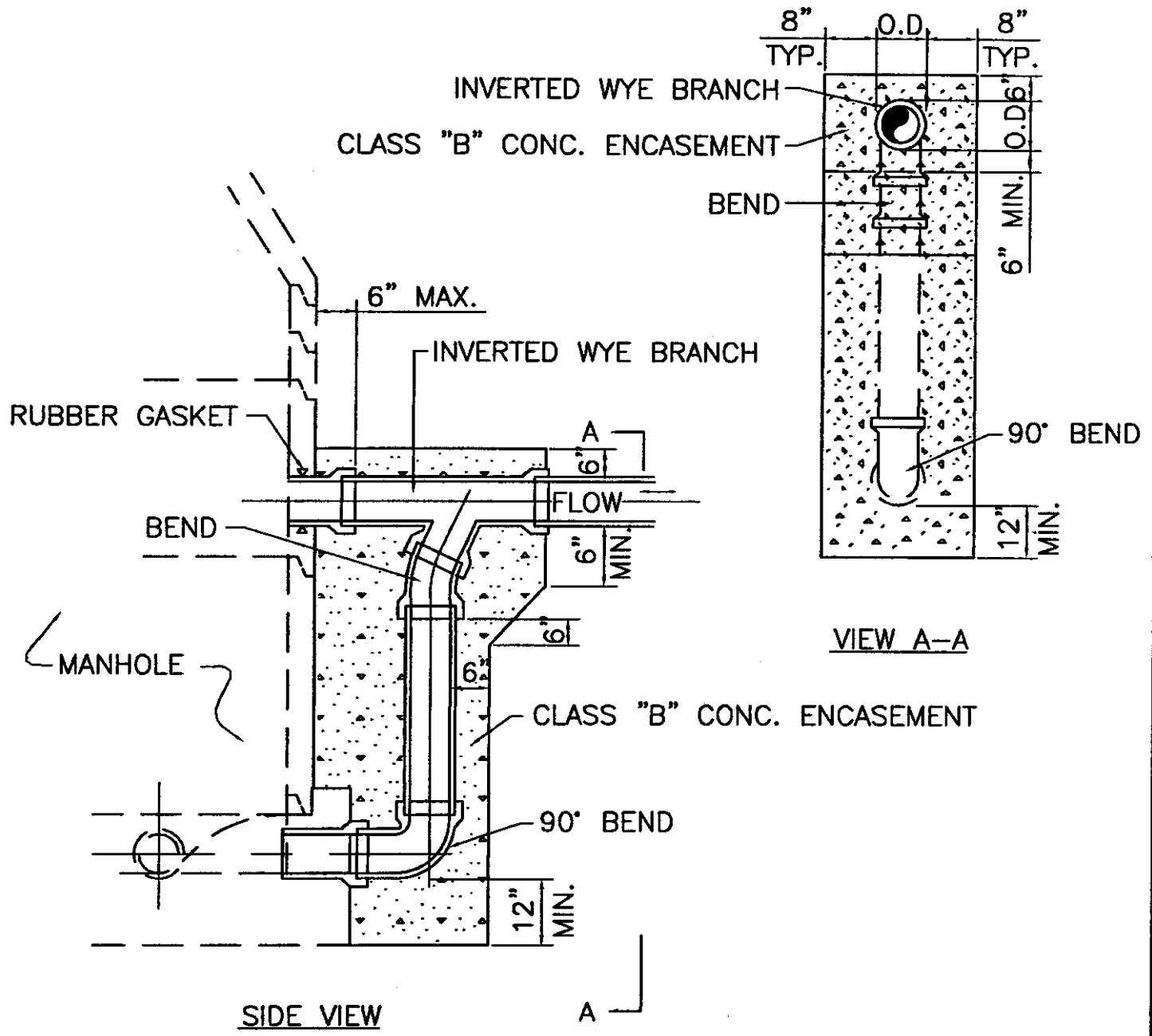

| | |
|--|----------|
| TYPICAL DETAIL | |
| <u>DROP CONNECTION TO STANDARD MANHOLE</u> | |
| MARKELYSBURG BOROUGH | PLATE XI |

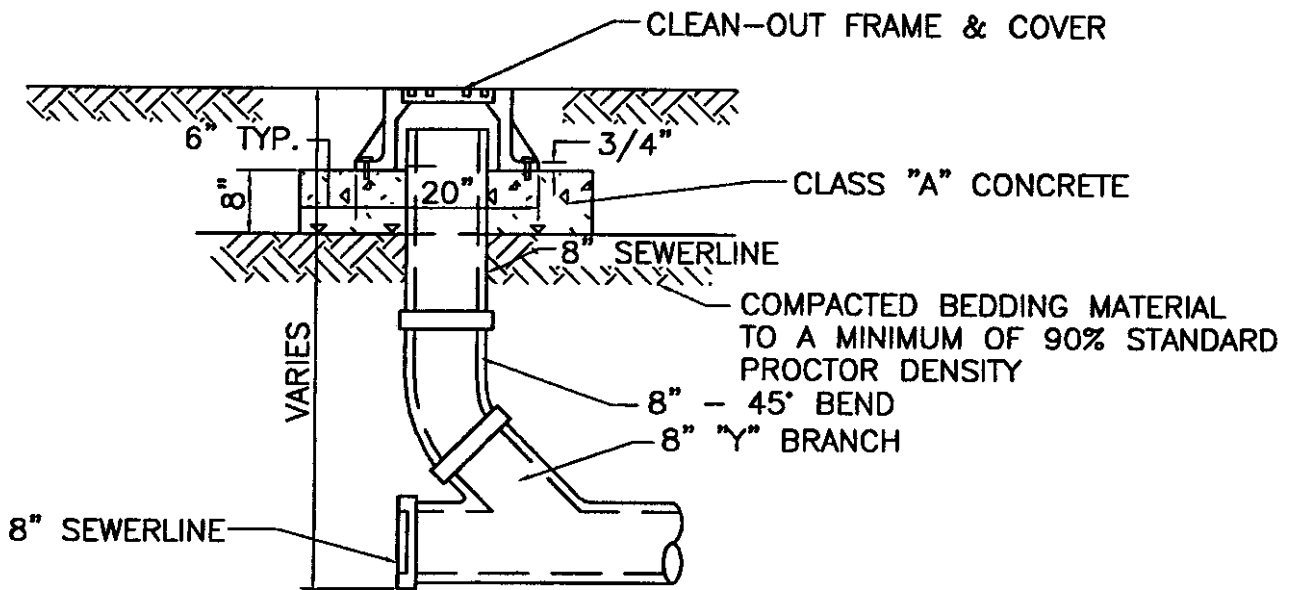
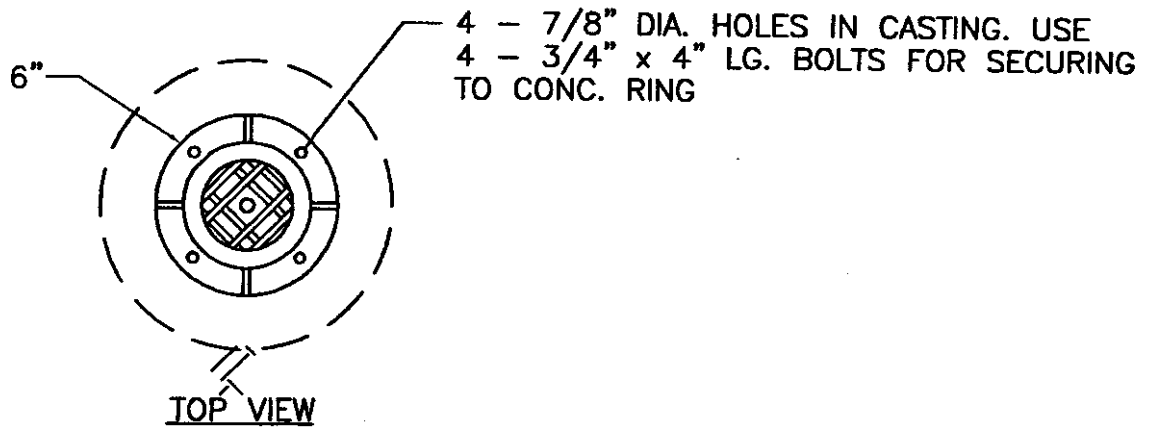

SIDE VIEW

STANDARD CLEAN-OUT
N.T.S.

| | |
|---------------------------|-----------|
| TYPICAL DETAIL | |
| <u>STANDARD CLEAN-OUT</u> | |
| MARKELYSBURG BOROUGH | PLATE XII |

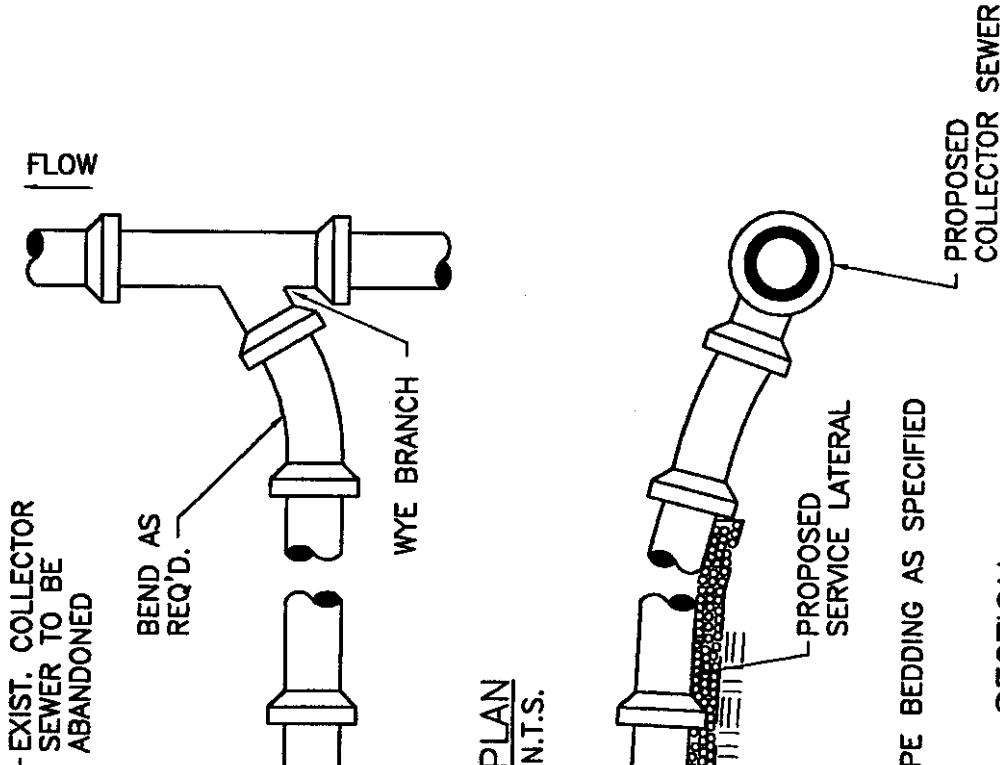

PLAN
N.T.S.

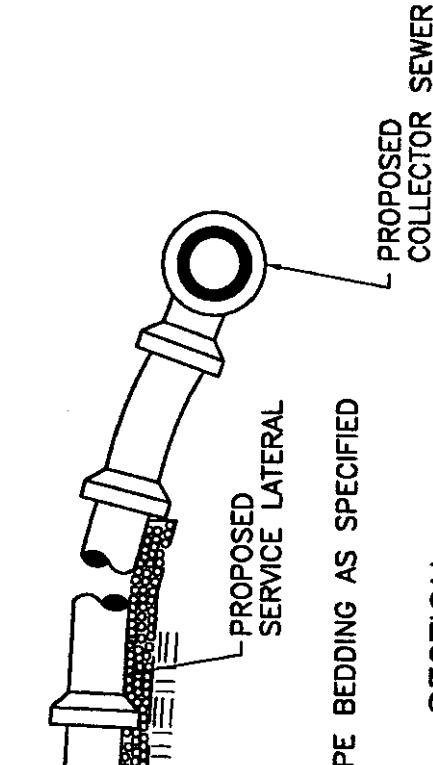

SECTION
N.T.S.

6" THICK CONC. SUPPORT TO EXTEND 6" BEYOND WIDTH OF TRENCH ON UNDISTURBED EARTH (TYP)

REMOVE EXIST. PIPE PLUG END WITH CONCRETE

NOTES:

1. MINIMUM SLOPE: 1/8" PER 1'-0" FOR 6" LATERAL
2. CONNECTION TO SEWERS SHALL BE ENCASED IN CLASS 'C' CONCRETE. MIN. OF 6" ON ALL SIDES AT COLLECTOR SEWER.

TYPICAL DETAIL

TYPICAL SERVICE CONNECTION TO NEW COLLECTOR SEWER

MARKELYSBURG BOROUGH

PLATE

XIII

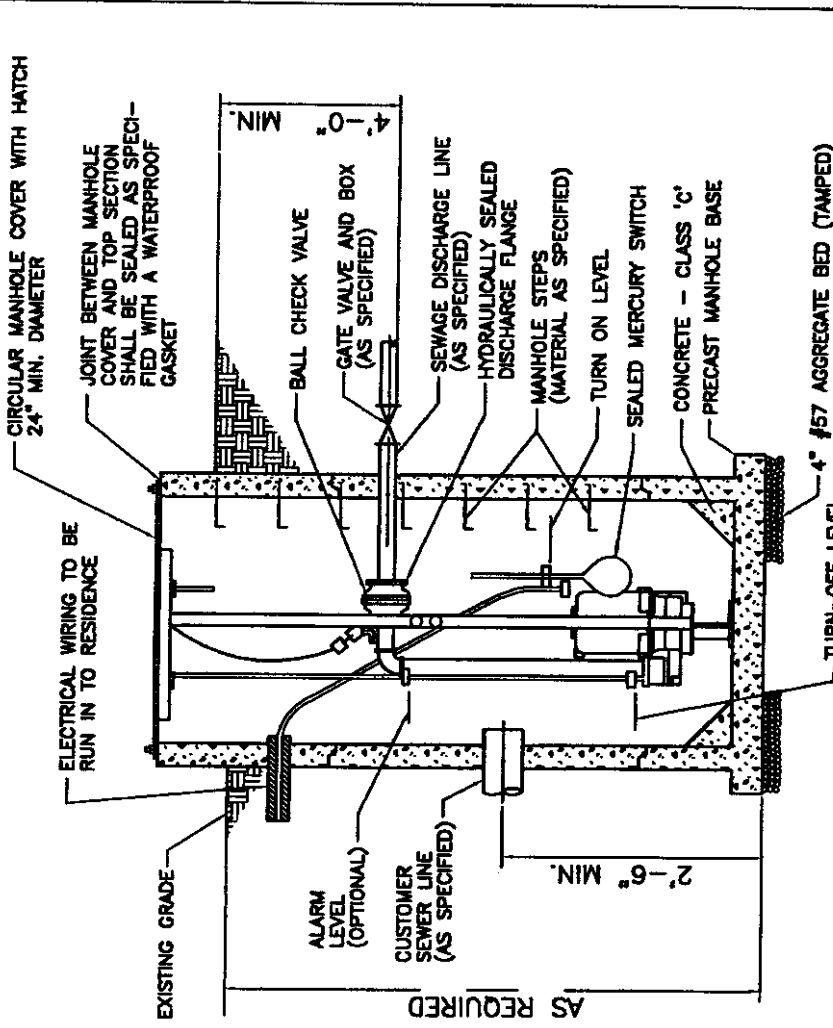

NOTE: 1. PRECAST CONCRETE MANHOLE SECTIONS MANUFACTURED IN ACCORDANCE WITH A.S.T.M. SPECIFICATION C478-64T, 3'-0" MIN. DIAMETER

SECTIONS

GRINDER PUMP INSTALLATION
OUT-OF-DOOR
N.T.S.

| | |
|--|-----------|
| TYPICAL DETAIL | |
| GRINDER PUMP INSTALLATION OUT-OF-DOOR | |
| MARKELYSBURG BOROUGH | PLATE XIV |

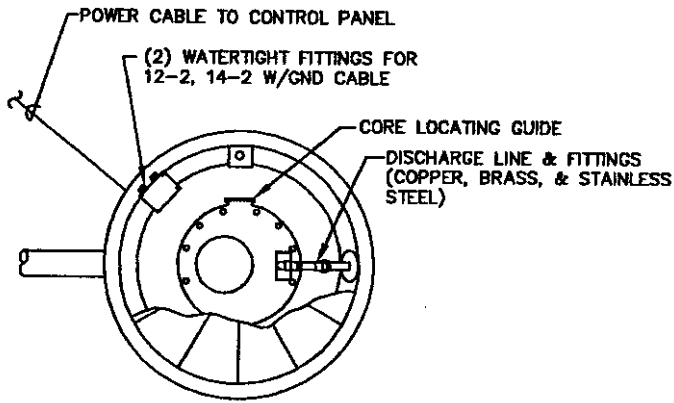

PLAN

NTS.

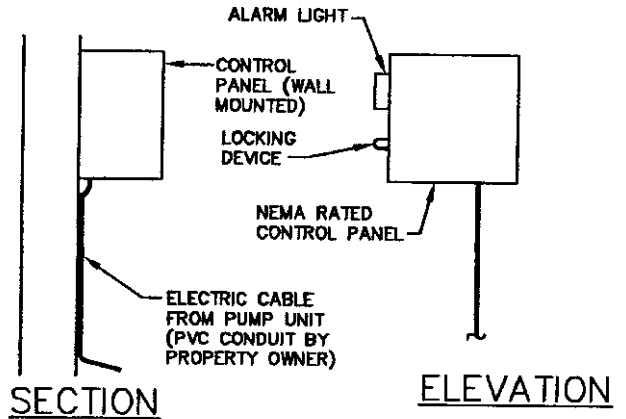

SECTION

ELEVATION

CONTROL PANEL

NTS.

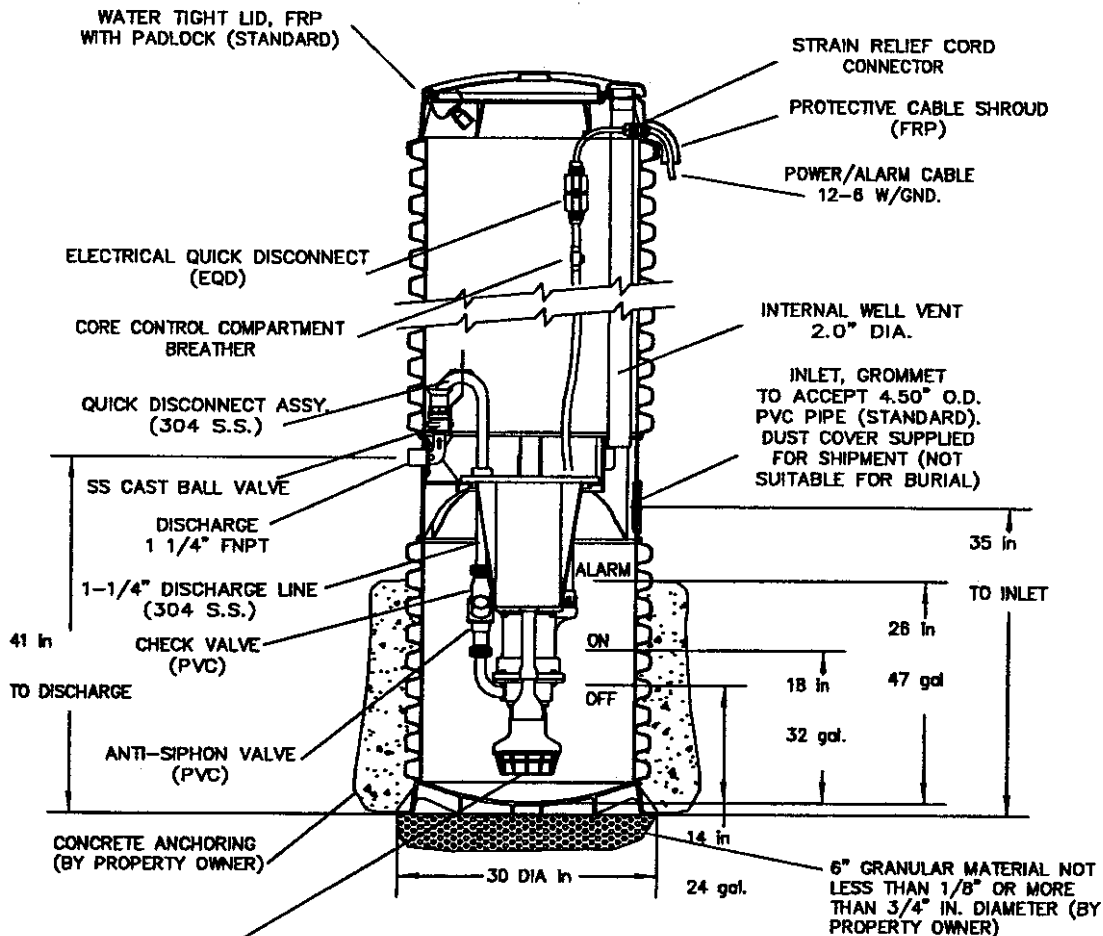

SEMI-POSITIVE DISPLACEMENT TYPE PUMP
DIRECTLY DRIVEN BY A 1 HP MOTOR
CAPABLE OF DELIVERING 9 gpm AT 138' T.D.H.
(34 ipm AT 42m T.D.H.)

TYPICAL DETAIL

GRINDER PUMP INSTALLATION
OUT-OF-DOOR

MARKELYSBURG BOROUGH

PLATE

XV

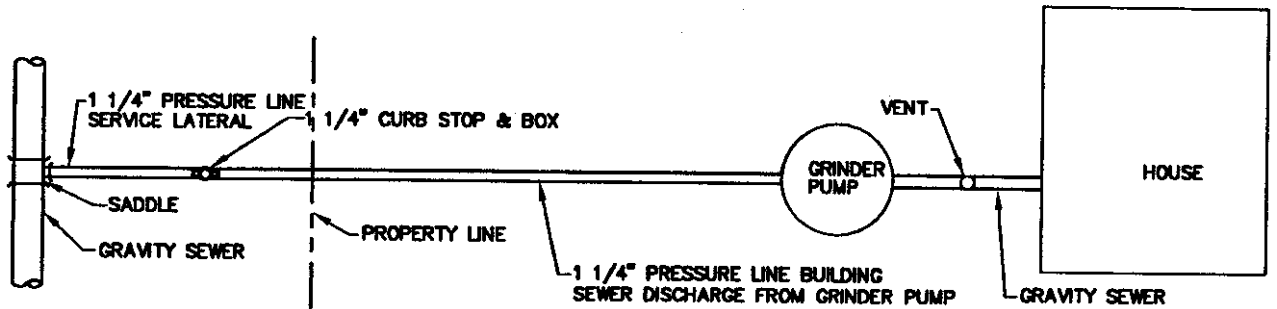

PLAN
N.T.S.

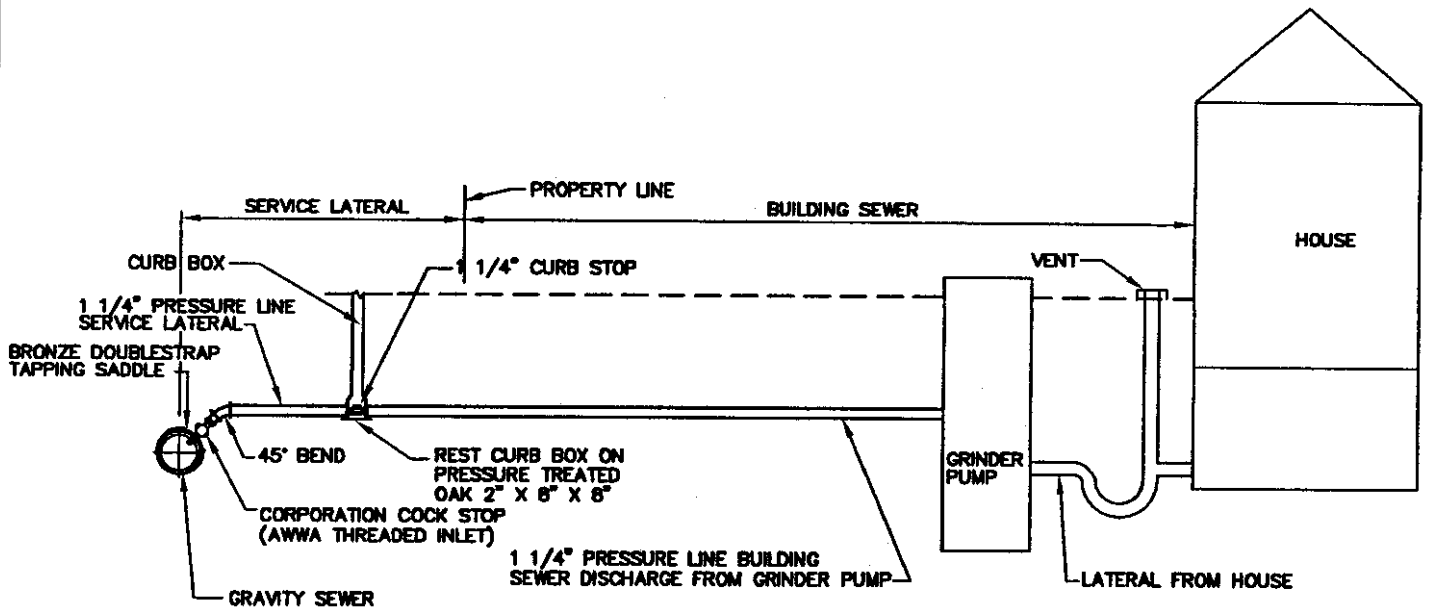

SECTION
N.T.S.

| | |
|---|-----------|
| TYPICAL DETAIL | |
| <u>GRINDER PUMP DISCHARGE</u> <u>CONNECTION TO</u> <u>GRAVITY SEWER</u> | |
| MARKELYSBURG BOROUGH | PLATE XVI |

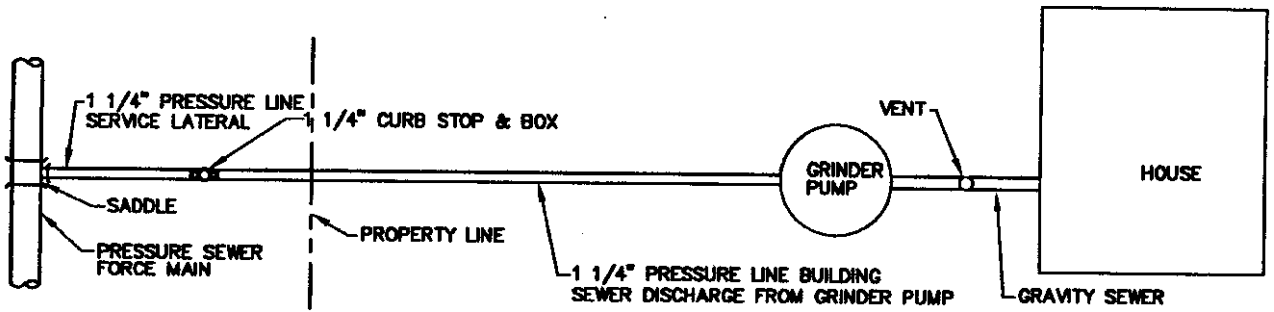

PLAN
N.T.S.

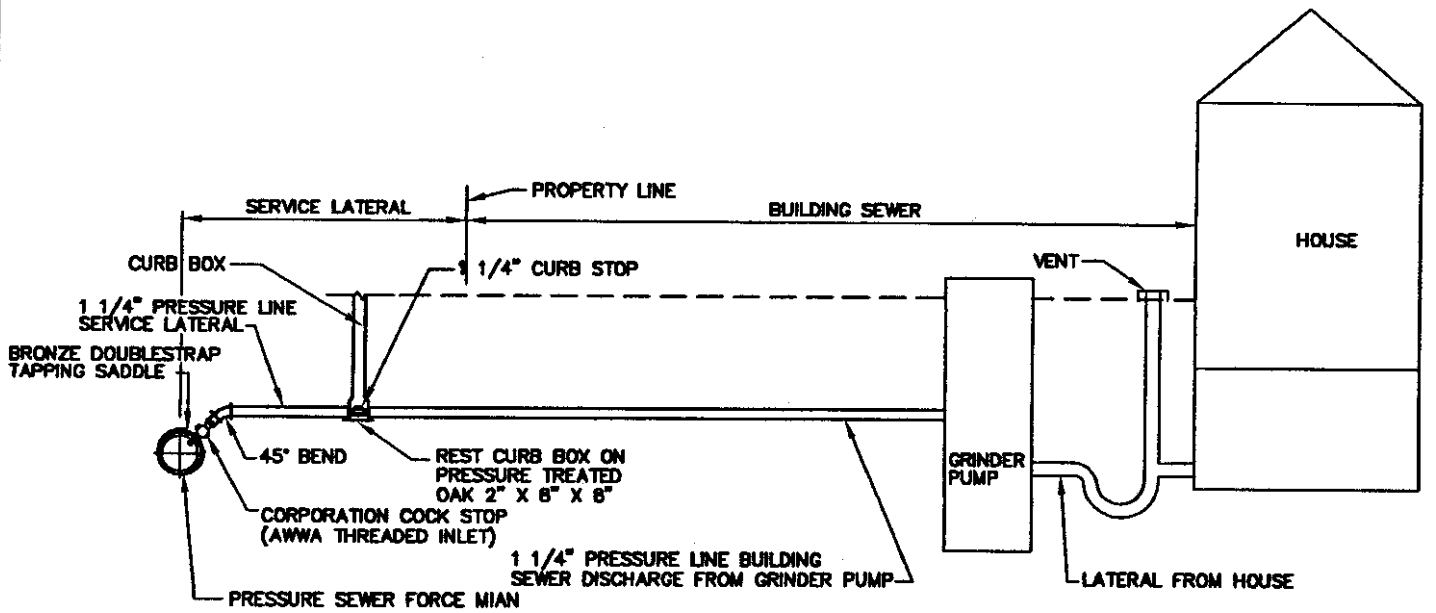

SECTION
N.T.S.

| | |
|---|------------|
| TYPICAL DETAIL | |
| <u>GRINDER PUMP DISCHARGE</u> <u>CONNECTION TO A PRESSURE</u> <u>SEWER FORCE MAIN</u> | |
| MARKELYSBURG BOROUGH | PLATE XVII |

SEWAGE CONNECTION APPLICATION

Borough of Markleysburg

PO Box 25, Markleysburg, PA 15459-0025

Phone: (724) 329-1459 Fax: (724) 329-1459

Email: sewage@markleysburg.pa.us

Sewage Service Application (for Connection to the Sanitary Sewer System)

Application Date:

Contact Information

Property Owner:

Property Owner Address:

City:

State:

Zip Code:

Phone Number:

Alternate Phone Number:

E-mail Address:

Service Location

Service Address:

City:

State:

Zip Code:

Municipality:

Boro of Markleysburg Henry Clay Township

Tax Parcel I.D.:

Type of Structure:

New House Mobile Home

Multi-Family Commercial

Estimated Completion Date:

Tap-in Fee:

\$1,000.00 per EDU (Equivalent Dwelling Unit)

Service Rate:

\$28.00 per EDU (Equivalent Dwelling Unit) or as amended

This Application for or the issuance of a sewage permit does not give the property owner the right to begin construction of any structure. A building permit must be secured from the Fayette County Office of Planning, Zoning and Community Development if you plan to build in the Borough of Markleysburg prior to beginning construction. A building permit must be secured from the Henry Clay Township Zoning office if you plan to build in Henry Clay Township, prior to beginning construction. Furthermore, the property owner must comply with all other applicable Borough or Township, State and Federal regulations and laws.

I certify that the above information is correct and that the premises covered by this application will have no industrial, institutional or other non-domestic wastewater discharges and that I/We will conform to the "Sanitary Sewer System Rules and Regulations" Governing the installation, construction, and use of the Sewer System, issued November 2004 and as amended.

Signature of Applicant(s)